

SPEECH SOUNDS IN ANDAMANESE :

A DESCRIPTIVE STUDY

**Dissertation submitted to the
Jawaharlal Nehru University in partial fulfilment
of the requirement for the award of the Degree of**

MASTER OF PHILOSOPHY

CHANDAN KUMAR



**Centre of Linguistics and English,
School of Language, Literature and Culture Studies
Jawaharlal Nehru University
New Delhi –110067
India
2001**

***DEDICATED TO
MY HONEY FRIEND.....***

Dated: 19th July, 2001

DECLARATION

This dissertation entitled **Speech Sounds in Andamanese: A Descriptive Study**, submitted by me for the award of the degree of **Master of Philosophy** is an original work and has not been submitted so far in part or full, for any other degree or diploma of any University.



(Signature of Candidate)

NAME: CHANDAN KUMAR

CENTRE: Centre of Linguistics and English

SCHOOL: School of Language, Literature and
Culture Studies

UNIVERSITY: Jawaharlal Nehru University



CENTRE OF LINGUISTICS & ENGLISH
SCHOOL OF LANGUAGE, LITERATURE & CULTURE STUDIES
जवाहरलाल नेहरू विश्वविद्यालय
JAWAHARLAL NEHRU UNIVERSITY
NEW DELHI-110067 INDIA

21st July 2001

CERTIFICATE

This dissertation entitled **Speech Sounds in Andamanese: A Descriptive Study**, submitted by **Chandan Kumar**, Centre of Linguistics and English, School of Language, Literature and Culture Studies, Jawaharlal Nehru University, New Delhi, for the award of the degree of the **Master of Philosophy**, is an original work and has not been submitted so far, in part or in full, for any other degree or diploma of any other university.

This may be placed before the examiners for the award for the degree of Master of Philosophy.

Prof. R.S. Gupta
CHAIRPERSON

Prof. Vaishna. Narang
SUPERVISOR

ACKNOWLEDGEMENT

At the very outset, there is absolutely no hesitation in denying the fact that initially I was not totally confident in taking up this research. The difficulties and problems I would face were clear to me at the very start. There is very little literature available, and even the collection of data is an arduous task, especially given the fact that only a handful of native speakers of this language remain today. However, my supervisor, Prof. Vaishna Narang not only motivated me but also helped me in restoring my confidence to take up this challenging work. I am eternally grateful to her for providing me with her own data bank. Furthermore, her insights, encouragement, support and remarkable ability to extract the best from an individual have been invaluable, and without it, this work would never have seen the light of day.

I am highly indebted to the Director, C.I.I.L, Mysore, Mr. O. N. Kaul, Prof. V. Gyansundaram, and Dr. Rajaram for sharing with me their experiences of this language, and for providing me with their data. I am also grateful to Mr. S. Manoharan, whom I met personally, for sharing information about the language, land and people of the Andamanese, and for his suggestions regarding data collection.

I would like to thank the faculty and staff of C.L.E for their help and guidance on matters- academic and official- over the last four years.

My special thanks are due for my friends Keshari and Tahseen who not only helped in transcribing the data and editing but also gave me valuable suggestions throughout the work. Thanks to Cherry, Khalid bhai, Zia, Reena, Swapna, Reji, Pallavi, Pramod and many more for the enjoyment they have given me in J.N.U. I thank my lovely

juniors- Chaitra, Sumedha, Aarti, Samar and Aditya for all the help they provided during the research, and to my respected seniors- Shailendra bhaiya and Ajit bhaiya for their valuable suggestions. I thank my childhood friend Alok and typist Ashok for helping in this whole dissertation typed.

A simple thanks remain too small to express my deep love and gratitude to my parents, brother and sisters, who in spite of difficulties, have always have supported me to continue my academic pursuits. And of course, this acknowledgement would not be complete without mentioning, Birju and Madhumita who have always been the constant source of inspiration and motivation and have supported me in whatever I have done who have always allowed me to keep a smile on my face.

Chandan Kumar

CONTENTS

Chapter One:	1-14
<i>Introduction</i>	
1.1 Outline	1
1.2 Land and people	3-8
1.3 Andamanese Language	8-11
1.4 Existing Research	11-14
1.5 Aims and Objectives	14
Chapter Two:	15-26
<i>Methodology</i>	
2.1 Introduction and Background	15-22
2.2 Aims and Objectives of the Present study	22
2.3 Delimiting the scope of research	22-23
2.4 Methodology of the Present study	23-26
2.5 Chapterisation	26
Chapter Three:	27-87
<i>Analysis and Description of Speech Sounds</i>	
3.1 Segmental Phonemes	27
3.2 Consonants	27-59
3.3 Vowels	60-74
3.4 Syllabic Structure	75-87
Chapter Four:	
<i>Summary and Conclusion</i>	88-96
<i>Bibliography</i>	97-100
<i>Appendices</i>	101-126

CHAPTER ONE

INTRODUCTION

1.1 Outline

The aim of this dissertation is an attempt to formulate a descriptive study of the speech sounds in the Andamanese language. The Andamanese group of languages are presently nearly on the verge of extinction, in particular, due to the rapidly decreasing population as well as due to language shift and contact with other languages. In recent years for example, it has been seen that a large number of Andamanese speakers, especially the young, prefer to speak a Port- Blair dialect of Hindi rather than Andamanese. Even the older generations, who still largely do speak Andamanese, are today incorporating the vocabulary of Hindi and even to some extent, Bangla into their verbal repertoire. Language is a system of communication that binds people together through centuries of experience; a loss of language at its basic structural level therefore entails a loss in specialised knowledge of language that only a native speaker possesses. Further, it has been reported that there are about 6000 languages spoken in the world today, and over half of them will not be spoken by the end of the next century. This fact alone underscores the urgent and important need for description of languages, before they are no more and become extinct. This study will thus aim at a study of the speech sounds of the Great Andamenese language, which will be useful for further linguistic research.

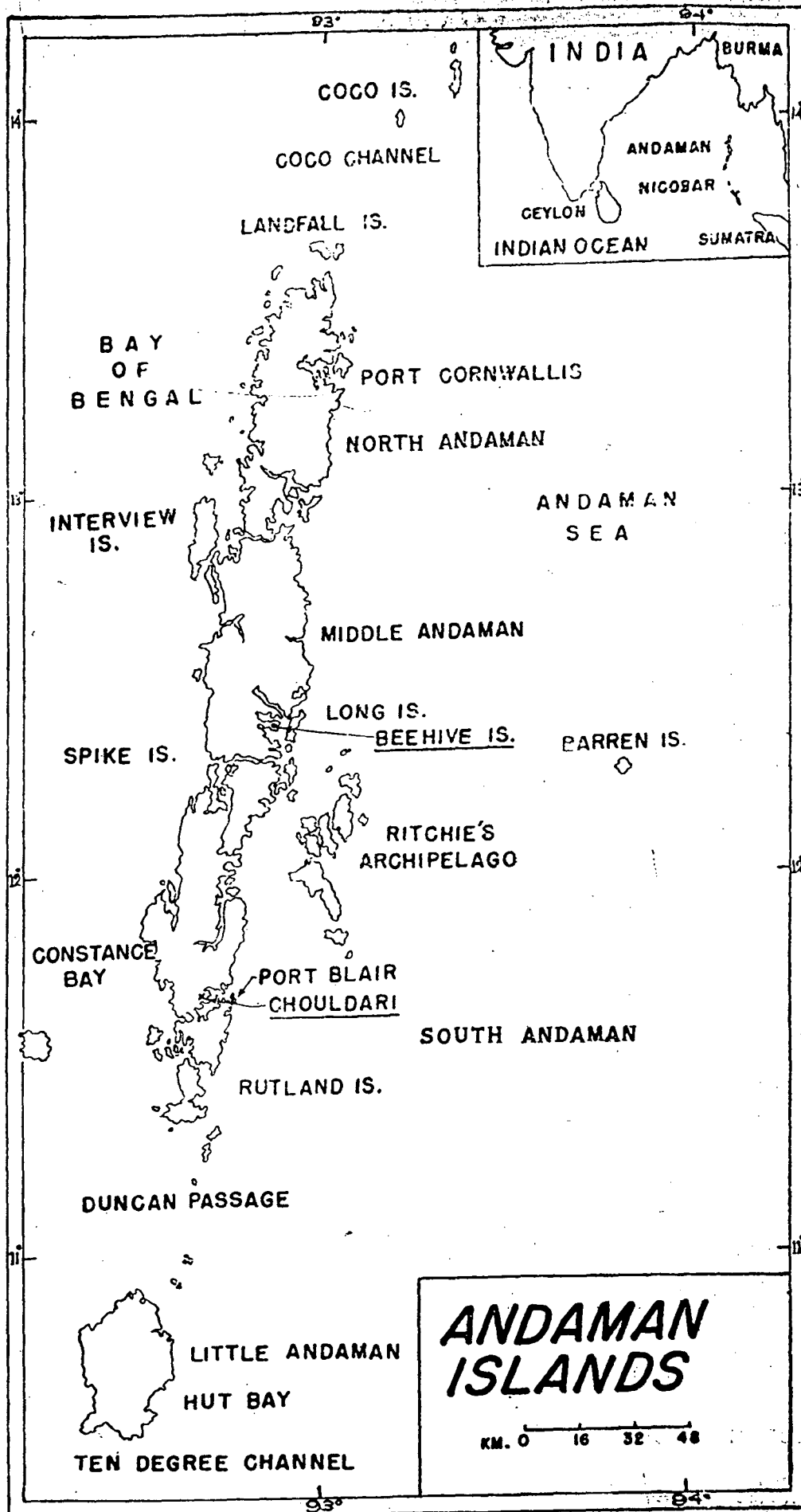

Fig. 1. Showing locations of Chouldari and Beehive midden sites

1.2 Land and People

1.2.1 Geographical Location

The Andaman and Nicobar islands form a part of the Indian sub-continent and consist of a chain of approximately 223 islands, located in the Bay of Bengal at the south-east of the Indian sub-continent- between $10^{\circ} 13'$ - $10^{\circ} 30'N$ latitudes and $90^{\circ} 15'E$ - $93^{\circ} 10'E$ longitudes. These islands are the homeland of one of the most primitive communities in the world, a community that has till recently managed to retain most of its ancient and primitive customs, far removed not only from those of mainland India, but even from the capital Port Blair. The chain of islands that make up a total length of 353 kms. are separated from each other by innumerable narrow passages, which look like a "closely knitted elongated stretch of land."(Dutta, 1978, p.7) The average breadth of the islands is 24 kms., with an estimated total land area of 6340 kms. Of this, approximately 2415 sq. kms. are covered by dense tropical growth of evergreen and deciduous trees.

The Andaman Islands are divided into two main groups of islands, Great Andaman and Little Andaman. Great Andaman is further subdivided into three separate groups- North Andaman, Middle Andaman and South Andaman, together making up a length of about 258 kms. The maximum length and breadth of Little Andaman is 42 kms and 26 kms respectively. The entire land surface of the Andamans is hilly, enclosing

narrow valleys; there are no rivers as such, and during the monsoon period, the islands are drained by non-perennial showers.(Ibid., p.8) The capital, Port Blair is situated at a distance of 1255 kms from Calcutta and 1135 kms from Chennai and it is only in recent times that some influence of this mainland is beginning to become visible in some of the tribes. (See map on pp. 2)

1.2.2 Andamanese People

The population of the Andaman and Nicobar islands can be divided into two groups. While the people inhabiting the Andaman group are called 'Negrito', those of the Nicobar group are known as 'Mongoloids'. It is this latter group that has somewhat accepted the fact that change is integral to the cultivation of the life process, and this is generally cited as the reason for their prosperity and the multiplication of their population.(Chakraborty, 1990, p.i) On the other hand, the Negrito population of the Andaman has been further sub-divided into two groups – those of the Great Andaman and those of the Little Andaman. The Little Andaman group comprised of the Onge, Jarawa and Sentinel tribes while the Great Andaman group was made up of ten tribes i.e. Cari, Kora, Bo, Jeru, Kede, Kol, Juwai, Puchikwar, Boli and Bea. Today, however the population of the island has depleted so much that there is not a single surviving member left of 8-9 of these tribes, and the few remaining people claim to be members of the Jeru tribe. From a population of 625 (1901 census), the last century has seen

this indigenous tribal population come down to a mere 32,(in 1993, when the data was recorded) with very severe prospects of extinction.

Anthropologists today, especially after seeing the severity of the population situation have started undertaking a number of studies on these tribes- in particular, they are attempting at a documentation of their language, culture, traditions, folklore etc. In these studies, a history of these islands also occupies an important place. The first mention of the existence of these groups of islands can be found in the 2nd century, in Ptolemy's *Annotated Atlas of the World*. He referred to these islands as 'Buzacata'. Subsequently, these islands are referred to by Itsing, a Chinese Buddhist monk of the 7th century, as 'Andaban', and also in the writings of Marco-Polo, Frair Odric, Nicolo Conti and others. However, As Dilip Chakraborty notes, the first historical account covering these islands occurs in the travel and adventure narratives of two Muhammadan wanderers of the ninth century, in their journeys across India and China.(Chakraborty, 1990, p.2) They referred to these islands as "being inhabited by Negritos"(Mouat, in Chakraborty, Ibid.)Etymologically, the name Andaman has been said to have been derived from 'Hanuman'. The Malays referred to the Andamanese as 'Handuman' or 'monkey-people'-a corrupted version of the original 'Hanuman'; Marco-Polo called them 'Angamanain- probably an oblique Arabic dual word indicating the two Andamans. The Chinese and Japanese have known them since the first millennium A.D, and called it

Yang- to Mang and Andaban respectively. All these references however are mostly conjectural and the present form that is Andaman has probably emerged out of a combination of all these names (Manoharan, 1989, pp.2-3). The first authentic record of the history of the Andaman islanders is only available after the British came into contact with them in 1788. Other than these foreign documentations, the Andaman and Nicobar Islands have also found mention in the works of Krishnaswamy Iyengar. He stated that king Rajendra Chola II, one of the great kings of South India also visited the Nicobar islands during his expedition in the 11th century A.D; as does the Tamil epic poem *Manimekalai* (2nd century B.C)- albeit indirectly. These various documents all go on to prove the fact that these islands have been existing and have been inhabited since a very long time.

It is only however from the late 18th century onwards that these islands began to take on an interest for the then rulers of India, the East India Company. It was in 1789 that Lord Cornwallis ordered for a penal settlement to be set up in these islands, and the entry of Lieutenant Archibald Blair with his establishment thus signalled the beginning of the entry of non-natives into the islands. The islanders, who had always been wary of outsiders, did not accept the move warmly. The hostility continued for years, until the Britishers, owing to the high death rate, finally abandoned the settlement in 1794. Following the Sepoy Mutiny of 1857, the penal community was once more established on the islands; this time

however, the native tribes did not hide their hostility, and organised a well-planned attack on the settlement. But the manner of retaliation led to one of the worst cases of colonial genocide. Subsequent spreading of diseases like bronchitis, syphilis, measles etc. due to increasing contacts between natives and non-natives reduced the latter's resistance powers and caused large - scale deaths. Other reasons for population decline included the consumption of opium, again an outside influence, which contributed to lower birth rates and the indiscriminate clearing of forests, making the tribals easy prey to illnesses like malaria (Chakraborty, Ibid., p.10). These were the major factors responsible for the sharp decline in the population of these islands from a figure of 3000-3500 in the mid - nineteenth century to a mere 625 at the turn of the 20th century. Since then, the population decline has continued as a multiplier effect. Many young men of reproductive age had lost their lives during various battles with colonisers. The Japanese massacre of the Andamanese during the Second World War also contributed to this steady and continual decline of the indigenous population.

V. Gyansundaram and K. S. Rajyashree have, in their study, titled 'Language Loss/Maintenance: A Case Study of Andamanese' attempted to portray this disturbing trend of population loss during the course of the 20th century:(V. Gyansundaram and K. S. Rajyashree, 2000,p.74)

Year	1901	1911	1921	1931	1951	1961	1971	1975	1988	1998
Population	625	453	209	90	23	19	24	23	28	36

The sharp decline evident in the first half of the century corroborates the above facts. It is indeed a great tragedy that is man-made rather than natural means that are largely responsible for the perilous state that these tribes today find themselves in.

1.3 Andamanese Language

A question that has led to tremendous debate among linguists, anthropologists and researchers is whether the Andamanese language can be classified as an independent language family. The language is classified in the census as "an unclassified language" spoken by "a few remaining individuals of the tribe of the same name"(Nigam, 1972, in Manoharan, 1989,p.173). This is more or less a repetition of Radcliff-Brown's claim that "the Andamanese languages constitute a separate family having no other apparent affinity with any other family of language"(Radcliff-Brown, 1964, p.495). Further, he also pointed out that within this family, all the languages are closely related to each other, and have the same grammatical and root structure (Chakraborty, *op cit.* p.8). Recent studies have corroborated this point further, with the grouping of the various language communities of India into five convenient language families viz: Andamanese, Astro-. Asiatic, Dravidian, Indo-Aryan and Tibeto-Burman.

Manoharan has grouped the Andamanese family of language into two main groups, each with its own sub-division, as seen in the tree diagram on the following page (Manoharan, 1989, p.173).

Traditionally, each tribe has had its own distinct language and questions of identity even today continue to be closely linked to language use, as boundaries for each tribe are very clearly defined. It is impossible for any individual from one tribe to visit an area belonging to another tribe, without taking prior permission. Each language, similarly, has its own distinctive and clearly defined features - at times we even see the existence of a number of different dialects within a particular tribe (Ibid., p.5).

Radcliff- Brown's seminal study gives the example of one such tribe:

In the Aka-Bala tribes there were two dialects, one in the southern half of the Archipelago, which was allied to Aka-Bea, and the other in the northern half, showing affinities with Aka-Puchikwar. Even in a small tribe as the Aka-Cari, it would seem that there were differences of dialect. Thus, even from the point of view of language, the tribes were not entirely homogeneous.(Radcliff-Brown, in Manoharan, 1989, p.5)

Tribal identity and languages should not therefore be seen as similar or homogeneous. At one level, we see certain tribes, whose members were bilingual or even tri-lingual (when they would be able to speak the language of adjoining tribes as well), while at the other end of spectrum, many tribes living in distant areas or at a great distance from each other, did not even know of the existence of many of the others, let alone have an

ANDAMANESE FAMILY OF LANGUAGES

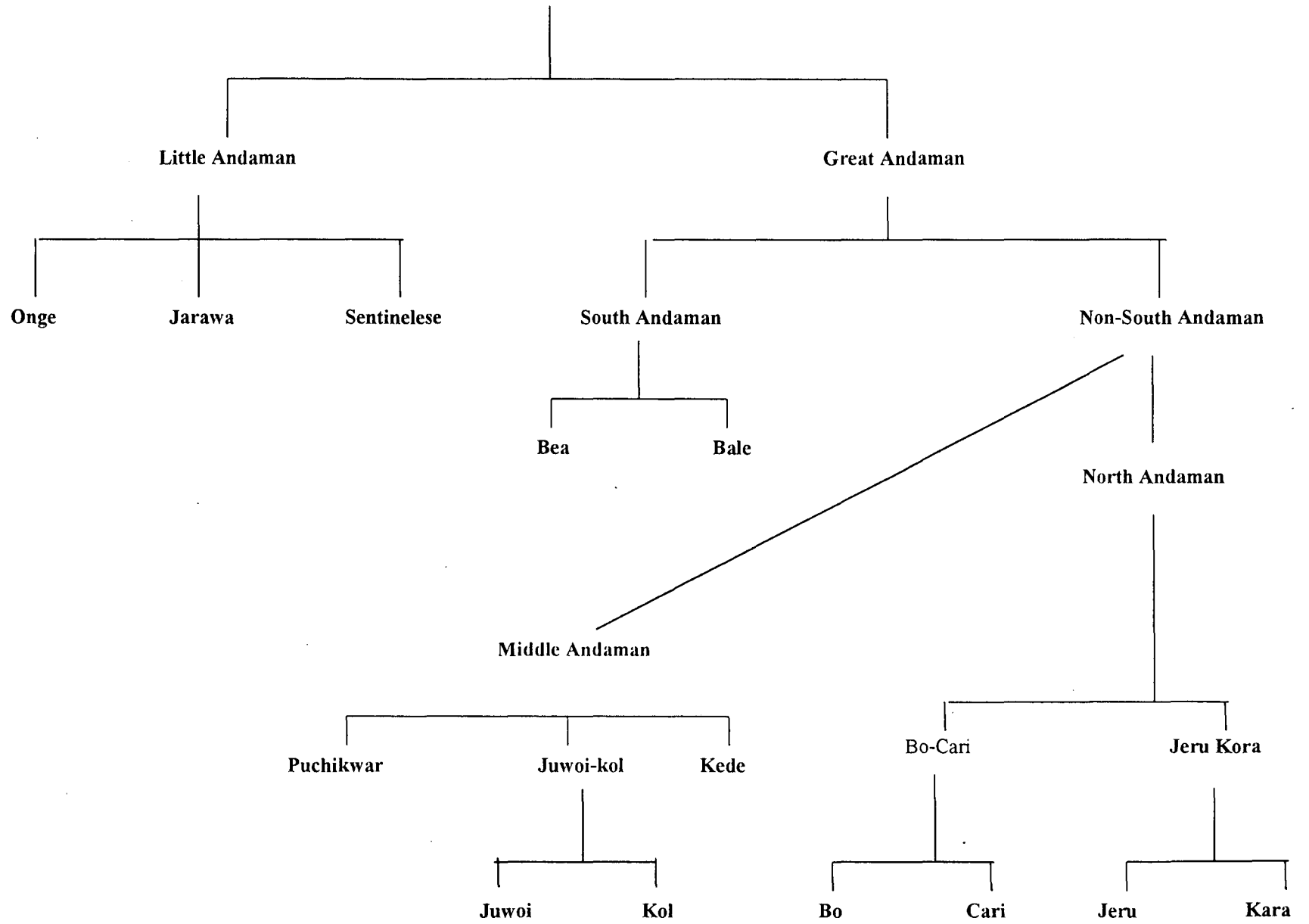

awareness regarding their language. Such complexities all combine together to provide for a fascinating and intriguing socio-linguistic study of the area.

1.4 Existing Research

Most studies that have been undertaken on the Great Andamanese are anthropological documents. The earliest works date from the mid 1860's, with works such as *Adventures and Researches among the Andaman Islands* (1836) by F. J. Mouat, *Manual of Andamanese Language* (1887) and *History of our Relations with Andamanese* (1889) by M. V. Portman, *Aboriginal Inhabitants of Andaman Islands* (1932) by E. H. Man and of course A. R. Radcliffe Brown's seminal anthropological work, *Andaman Islanders* (1922). Most of these works are on the society and culture of Andamanese, although Brown's work is considered indispensable for the purpose of any anthropological work on the region. In more recent times, Pratap C. Dutta's volume, *The Great Andamanese: Past and Present* (1978) offers a reconstructing of the cultural history of the islands, on the basis of material exhumed from the area.

F.J. Mouat's work not only offers a general description of the various islands and descriptions of encounters with tribals, but also deals with some of their characteristics, habitats and language, which he says "was barely sufficient for the expression of their few simple wants"(Chakraborty, *op cit* p.5). His work was followed by E.H.Man, who

made a special study of the language of the Beas and also compiled an extensive vocabulary of this language. M. V. Portman's Manual focuses on the various Andamanese dialects as spoken by each individual tribe. It begins with an introduction on the grammar of the region, starting with the basic alphabet and its pronunciation, and continuing with the idea of word formation, parts of speech and syntax. The grammar is a functional one, its main purpose being to serve for conversation as required by Government officials. Portman then goes on to compose an English-Andamanese dictionary, a comprehensive account of words as spoken by members of the various Great Andamanese tribes. The second and third part of the manual constructs a number of sentences regarding the weather, coastal and jungle life, food and drink, diseases and relationship; and finally concludes with a list of articles relating to food, essential items and names of trees in the area.

However S. Manoharan's *Study of Andamanese Language*, based on his fieldwork in 1976-77 is supposed to be the first proper linguistic study of the language. Till date, this study remains the most exhaustive study of the language, which serves as the benchmark for all succeeding research. He has divided his studies into two parts. The first part is a descriptive study while the second deals with a comparative and typological study of this language. In his study, Manoharan has set up 31 phonemes of which 28 are segmental phonemes. Out of these 28 segmental phonemes, 21 are

consonantal phonemes and 7 are vowel phonemes. He has worked out the phonemes by comparing minimal and sub-minimal pairs by using the distribution method.

S. Manorahan gives the following phonemic chart (Manoharan, *op cit* p.11).

Vowels:

	Front	Central	Back
High	i		u
High-mid	e		o
Mean-mid	ɛ		ɔ
Low		a	

Consonants:

		Bilabial	Alveo Dental	Alveolar	Retroflex	Palatal	Velar	Port Velar
	VL	p	t		t	c		k
Stop	VD	b	d		d	j		
	Asp		th					
	Slit	φ					x	
Fricative	Groove			s				
Nasal		m		n		ñ	n	
Lateral								
Flap								
Trill				r				
Semi Vowel		w				r		

However, it will also be worth mentioning the different phonemic systems evolved by various authors in their earlier works like Portman (1898),

Brown (1948) and Basu (1952). Manoharan's study too is not a very detailed study. None of the authors have done a detailed phonetic description. Moreover, most of these scholars were anthropologists and they did not possess enough phonetic understanding of the language.

1.4 Aims and Objectives of the Study

Based on past research, it can, therefore, be said that descriptions of the Andamanese language as available today are preliminary, highly inadequate, unexhaustive and superficial. However, they can serve as the reference material for a more exhaustive description of the phonetic and phonological study of Andamanese. For this purpose more data and more sophisticated tools and techniques need to be employed, especially for the vowels. The scope of the present research will be an attempt to provide a description of phonetic and phonological patterns of the language. Further, this study will constitute the first step towards a more serious and in-depth study of the language. This work would serve as a valuable base from which further research on various aspects of the language can be undertaken.

However, it has to be remembered that M. Phil being a time-bound study, it will not be possible in this case to undertake a very detailed research on the speech sounds of Andamanese. For present purposes therefore, I will be concentrating on the phonetic and phonological aspects of speech sounds in the language.

CHAPTER TWO

METHODOLOGY

2.1 Introduction and Background:

Methodology is the most important tool in any kind of research activity, whether subjective or data based. The term 'research' has been given a number of definitions by various academicians but the *Oxford Advanced Learner's Dictionary of Current English* probably offers the most succinct, generic description of the term, as

... a careful investigation or inquiry, especially through search for new facts in any branch of knowledge(p. 1069).

This continual search for the unknown, which governs research, is regarded by many as a "voyage of discovery"(Kothari, 1995, p.1). In academics however, research takes on a technical meaning in some subjects, where it comprises of various steps - of formulating a hypothesis, collecting, organising and evaluating data, analysing it in order to arrive at a conclusion and finally carefully testing the conclusions to see if they fit the formulating hypothesis. These various steps can be depicted through the following flow chart (Ibid., p.14) given on the next page.

Research can be grouped into four kinds of study - exploratory or formulative, descriptive, diagnostic and hypothesis testing. Explorative

Research Process in flow Chart

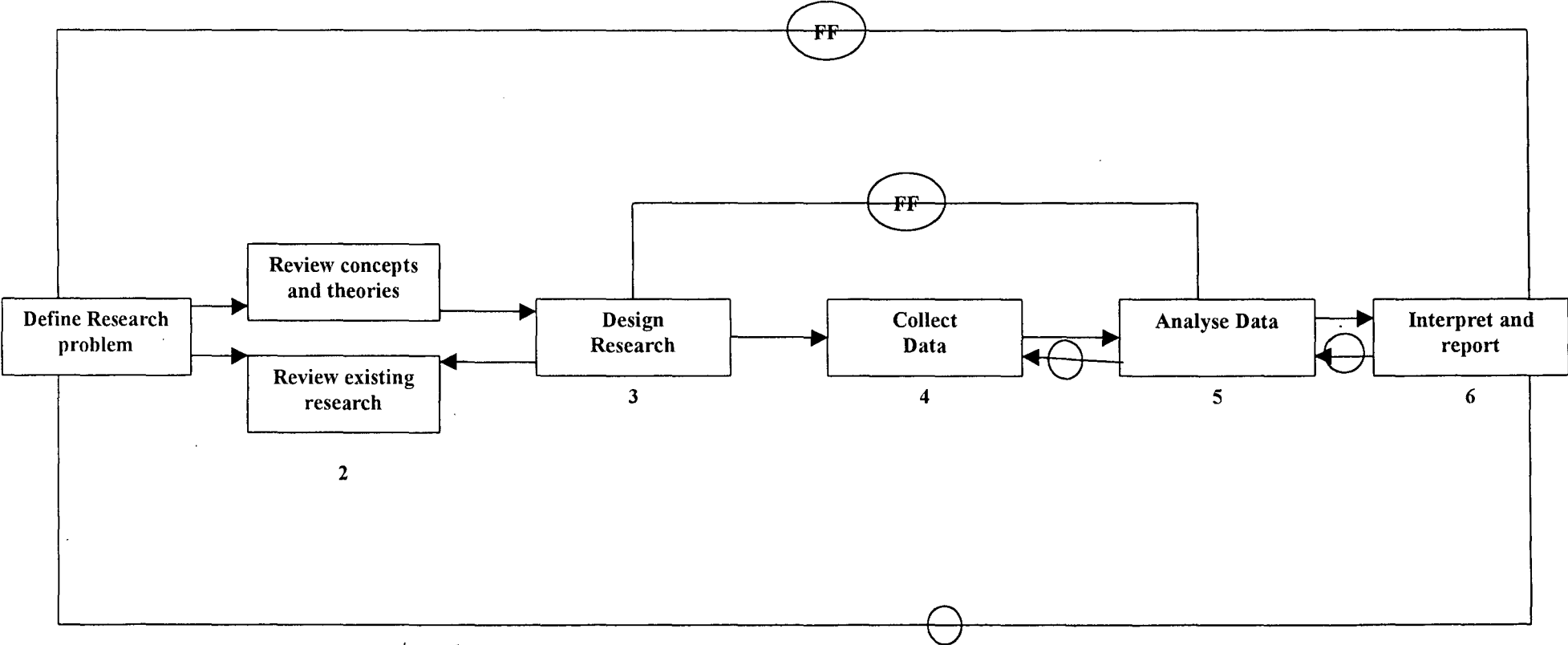

(F) = Feed back

(FF) = Feed forward

research is undertaken in order to gain new insights into an already existing phenomenon, descriptive research aims to accurately portray the characteristics of individual situations or groups, diagnostic research determines frequency of occurrence of an object or its association with another object, while hypothesis research aims to test hypotheses of causal relationships between variables. The present work of research, which is mainly data-based is more of the second type, aiming as it does at a classification and description of linguistic speech sounds in Andamanese. However, it is also diagnostic to a certain extent, as the analysis also focuses on the occurrence of certain sounds in various positions in the language.

Throughout the ages, as stated in the beginning, methodology has been a topic of serious debate amongst academicians. In linguistics and language studies, three clear phases may be distinguished: (i) pre-structuralist or traditional referring to the period before Saussure (ii) the structuralist trend emerging from the late nineteenth and early twentieth century onwards and (iii) the cognitive or post-structuralist phase, which became prevalent from the mid 1950's, especially with Noam Chomsky's ideas of transformational generative grammar.

For the traditionalists, language as a discipline was inferior to the twin topics of logic and philosophy. Focusing on the written, rather than the spoken form of writing, linguistic description lacked scientificity, objectivity and precision. During the nineteenth century, the study of language came to be known as “philology” and was mainly a comparative exercise, i.e. “the analysis of similarities and differences within a family of related languages” (Abrams, 1993, p.103). At the same time, language was also studied as a chronological history - analysis of the evolution of language families and changes within particular languages over a period of time - this is known as the diachronic method of language study. These methods initiated the first steps towards a more scientific study of language. By the end of the nineteenth and the beginning of the twentieth century however, another new trend was beginning to emerge, with concentration on the systematic interrelations between the components of a single language at a particular time, rather than over a period of time. This synchronic study gained its major impetus from the structuralist system of the study of language.

The emergence of structuralism in the late nineteenth and early twentieth century, in particular through the contributions of Ferdinand de Saussure, therefore, marked a tremendous advancement in the scientific study of language. For the structuralists, any kind of linguistic analysis is conducted

as empirical studies based on data, leaving little room for selectivity. It is therefore a data based objective, inductive and empirical study of language (Kovacs, 1981, p.211) and grammar is here derived from a process of inductive generalisation. The aim of such an approach is to provide a framework for the acquisition of reliable knowledge about language, rather than a systemisation or explanation of things that are already known or are assumed to be known (Garvin, 1972, p.7). Further, structuralists feel that any kind of language and data analysis had to begin from the sound system of the language, which allows scientific statements to be made. They construct models in order to learn about various objects. Models may be defined as constructed representation of concepts to describe and explain their structure and for function. They are of three types:

- a) models which have the objective of undertaking studies of the concrete process and phenomena in languages. This kind of study was first attempted by the Prague structuralists.
- b) research models, first made by the American descriptivists, which aim to lead linguists to the discovery of research phenomena.

c) models, the object of which are linguistic descriptions rather than processes and phenomena in languages or research procedures (Apresjan, 1973, p.112).

The second type of model, i.e. research models can be further subdivided into three groups based on the nature of the primary material:

(a) whether it is only text i.e. all the facts about the language are drawn from the text. These are known as classical decipherment models.

(b) whether it is a mixture of text as well as grammatical sentences. In this case, the linguist takes the help of an informant to decide whether the sentences are grammatical or not.

(c) whether it is not only the above two but in addition contains semantic invariants, i.e. in addition to the above, the informant in this case also determines whether any two sentences have the same meaning (ibid., p. 112).

Against the background of the structuralists emphasis on form and surface structure a new revolution came into action in the field of linguistic theory i.e. Chomskyan Linguistics. Chomsky succeeded in replacing many of the assumptions that were popular in structuralism. According to him, the

structuralists merely described, but did not explain linguistic facts. His contribution to linguistics is thus two fold. First, he questioned the goal towards which structuralist linguistic theory was oriented, and redefined the aims and function of grammar and secondly, he defined the form that this new grammar ought to take. Chomsky formalised the properties of his alternative system of grammatical description - transformational - generative grammar - with mathematical rigour and precision (Ballen, 1971, pp.392-393). The entire concept of grammar was redefined and new currents of thought were generated. Earlier structuralist theories, as discussed above, aimed to 'discover' or extract a grammar from the data collected from informants, and the ultimate goal of linguistics was to find rules to make up a perfect, objective language. Chomsky rejected these notions outright. For him, the grammar of a particular language is, in effect, a hypothesis on the principles of sentence formation in that language and represent a factual claim concerning the rules underlining the data that has been collected. Truth or falsity of the hypothesis is decided according to how well the grammar succeeds in organising data, how satisfactory an explanation it provides for the empirical observation, how far reaching the generalisations are and how successfully it can accommodate new data (Ibid.). In all, Chomsky therefore replaced

TH-9136₂₁



P24417151
P1

‘discovery’ with ‘evaluation’ and ‘inductive’ with ‘deductive’ emphasising all the while on ideas of rationality.

This present research work on the speech sounds of Andamanese language however is primarily a descriptive data - based study.

2.2 Aims and objectives of the present study

As already discussed in the preceding chapter, this present study aims to provide a descriptive study of the speech sounds in Andamanese, which would serve as a valuable base from which further detailed research on the language can be undertaken. Moreover, as this particular language is currently on the verge of extinction, it becomes all the more imperative that a detailed linguistic study is undertaken as soon as possible, before it is too late and Andamanese language is totally lost to us.

2.3 Delimiting the scope of research

Detailed research on all aspects of any particular language would naturally be a time-taking process, and Andamanese is no exception. Rather, in the case of Andamanese, the problems encountered in attempting such study become immense mainly due to three reasons. Firstly, undertaking fieldwork is a problem, as it requires government clearance to go to the field

and collect data. It also involves a lot of expenditure, which is difficult to arrange for, unless some kind of financial assistance is provided. Secondly, Andamanese being a language with few remaining native speakers, and with most of the younger generation preferring to speak dialects of Hindi, it is difficult to get data from a wide range of informants. And lastly, since not much work has been done on the language, there is little background material that one can rely on. A detailed study of this language will not only involve large amount of data collection but also an analysis of language at all levels i.e. phonetic, phonological, morphological and semantic. MPhil being a time-bound research programme of approximately a year, it is naturally not possible to do an advanced study on all these aspects. For the purpose of the present study, I have therefore limited the scope to a phonetic as well as bit of phonological analysis of the language.

2.4 Methodology of the present study

This present study has been conducted in two steps. The first step involves the elicitation of data and the second step involves an analysis of collected data. Data elicitation further has two parts:

(a) preparation and collection

(b) transcription

Preparation and collection: Data is primarily of two types - primary and secondary. Primary data are those collected from the source/speaker for the first time by the researcher and are thus original in character. Secondary data, on the other hand, refers to data already collected and/or reported in literature therefore having already been processed. Time paucity and financial constraints were major factors due to which no personal fieldwork of the region could be undertaken. The data used is therefore *primarily secondary*, derived out of four sources:

- (1) four cassettes containing approximately 500 words, recorded from the archives of Central Institute of Indian Languages (C.I.I.L.), Mysore. This data had been collected in 1993 by (C.I.I.L.), in order to prepare an Andamanese primer and for this present study, the data was recorded by qualified technicians in the sound - proof lab in the Institute. Five informants provided the necessary data - Noh Senior (Chacha) (male), Noh Junior (male), Jo (boy), Tong (girl), Likhu (male).
- (2) data collected by my supervisor, Prof. Vaishna Narang during her field trip to the Andaman and Nicobar Islands during 1996-97.
- (3) two primers and a glossary of Hindi-Andamanese words, with their meaning and phonetic pronunciation published by C.I.I.L., Mysore.
- (4) a basic word list already available from S. Manoharan's seminal study of the Andamanese language (Manoharan, 1989, pp.109-137).

Transcription: The second step in data elicitation is transcription. Transcription is a method of writing down speech sounds in a systematic and consistent manner, and this is also known as 'notation' or 'script' (Crystal, 1980, p.361). Transcription aims to record as accurately as possible all the utterances that the writer can perceive and identify in a stream of speech. Two main types of transcription are recognised- phonetic (broad) and phonemic (narrow). In the former, sounds are symbolised on the basis of their articulatory or auditory identity, while in the latter, the only units symbolised are those with a linguistic function, i.e. the phonemes. Transcription can never be perfect, however, experienced and highly trained linguistics can approximate gross phonetic facts at a more detailed level. Further, no two listeners, regardless of their competence, will ever transcribe all utterances exactly the same.

Keeping in mind these limitations, the collected data was transcribed by myself, and the entire list of words was then checked and rechecked thrice by a group of friends. At times, two of us would transcribe the same word simultaneously, thereby reducing the scope of error. For the transcription, I have used the International Phonetic Alphabet (IPA) symbols, an accepted ideal standard for transcription. Further, I have undertaken both narrow phonemic transcription as well as broad phonetic transcription.

The second step in the procedure is the analysis of data; which is undertaken after the entire process of transcription is over. As far as the

present study is concerned, the raw data was first categorised on the basis of initial sounds - for example - all words starting with /p/ were grouped into one. Then the minimal and sub-minimal pairs were extracted, and on the basis of that phonemic chart of vowels and consonants were made, and the data was classified in order that it could be analysed at a phonetic and phonological level. Each phoneme was classified on the basis of its occurrence in different positions, i.e. initial, medial, and final.

2.5 Chapterisation

The dissertation is divided into four chapters. The first chapter deals with history of the people and their language, existing research, aims and objectives and attempts to set out the guidelines and framework within which the study will be conducted. The second chapter undertakes a detailed description of methodology used in the research process. The third chapter deals with the analysis of speech sounds i.e. segmental phonemes, minimal and sub-minimal pairs, diphthongs, nasalisation, consonant sequence, syllabic sequence. The last chapter is a brief summary and conclusion, which will bring together all the data and analysis into some form of concrete logical conclusion.

CHAPTER THREE

Analysis and Description of speech sounds

A detailed analysis and description of speech sounds in Andamanese is being dealt in this chapter. The phonemic distribution and phonetic features of each one of the phonemes are given together. The first section deals with the consonants in which each one of the consonant is described primarily on the basis of articulatory terms. The second section deals with the vowel phonemes in similar format.

3.1 Segmental Phonemes:

The phonemic system of Andamanese is made up of thirty-two segmental phonemes of which twenty-four are consonants and eight are vowels. The inventory of segmental phoneme is as follows.

3.2 Consonants

As stated earlier twenty-four consonants can be recognised in this language. The consonants are classified on the basis of manner and point of articulation as given in the following IPA chart of consonant phoneme. (given in the following page). The vertical columns show the place of articulation and horizontal rows, the manner of articulation. The consonants require a certain degree of constriction in the vocal tract - either total occlusion or a narrowing. It is these different degrees of closure, which are known as manner of articulation.

Phonemic Chart: Consonants

Place of Articulation →

Manner of Articulation	Bilabial		Alveo Dental		Alveolar		Retroflex		Palatal		Velar		Post Velar	
	Vl	Vd	Vl	Vd	Vl	Vd	Vl	Vd	Vl	Vd	Vl	Vd	Vl	Vd
↓ S Plosive T Unasp O asp P	P	b	t	d			ʈ	ɖ			k	g		
	p ^h		t ^h				ʈ ^h				k ^h			
Affricates									c	j				
Nasals		m								ɲ		ŋ		
Trill							r							
Fricative					s				ʃ					h
Lateral							l							
Approximants		w								y				

3.2.1 Description and distribution of distinctive consonant phonemes

Stops:

It is a term used in the phonetic classification of speech sounds on the basis of their manner of articulation. Stop is produced with total occlusion in the oral cavity and with the velum raised so that no air escapes through the nasal passage. Because of these two closures the egressive air stream is momentarily completely dammed up, and unable to get through the vocal tract at all. The air is therefore, compressed behind the point of articulation, and will escape with a small explosion when the active articulator is removed from the contact with passive one. There are twelve stop consonant phonemes in this language. They are represented by /p/, /b/, /ph/, /t/, /d/, /t^h/, /t̚/, /d̚/, t^h/, /k/, /g/ and /k^h/. A brief articulatory description of each one of them on the basis of place and manner criteria is given below.

/p/ is a voiceless unaspirated bilabial stop. In articulating the Andamanese /p/ the air passage is completely blocked by closing the lip and raising the soft palate; the air is compressed by pressure from the lungs, and when the lips are opened the air suddenly escapes from the mouth, and in doing so makes a popping sound the vocal cords do not vibrate as a result voiceless sound is

produced. Regarding its distributions, it occurs in all the positions, viz. initial, medial and final

Initial	Medial	Final
/p ɔ:r/ 'bamboo'	/o:prɔ/ 'window'	/dup/ 'jingam tree'
/pi:r/ 'a cane'	/ərəkərapɬœ/ 'waist bone'	/bi:p/ 'dust'

Allophonic Variants: /p/ has two allophones (p), and (p').

(p) voiceless unaspirated bilabial stop occurs in all the positions as discussed above.

(p') voiceless unaspirated unreleased bilabial stop, sometimes occurs in the syllabic final position.

/su:p/ 'basket', /kəllaɬop/ 'snail' /ke:p/ 'spring'

/b/ is a voiced unaspirated bilabial stop. The Andameneese /b/ is produced exactly like /p/ described above, except that the force of exhalation is weaker and the vocal cords vibrate producing a voiced sound. Regarding its distributions, it occurs only in two positions, viz. initial and medial. It has no allophonic variation.

Initial	Medial
/bol/ 'leaves'	/Jubu/ 'fly'
/be:mo/ 'butterfly'	/kɔwbu/ 'umbrella'

/p^h/ is a voiceless aspirated bilabial stop. This sound is produced in the same way as that of /p/ except for the fact that sound is aspirated one. It gives a strong puff of air exhaled simultaneously with the release of the air stream stopped in the oral chamber. Regarding its distributions, it occurs only in two positions, viz, initial and medial. It has no allophonic variation.

Initial	Medial
/p ^h a:l/ 'wave'	/ʈɛp ^h e/ 'octopus'
/p ^h aʈka/ 'crow'	/ʈa:p ^h o/ 'type of tree'

/t/ is a voiceless unaspirated alveo-dental stop. It is articulated when the air passage is completely blocked by raising the soft palate and raising the tip of the tongue to touch the teeth-ridge, the air is compressed by pressure from the lungs, and when the tongue is removed from the teeth-ridge, the air suddenly escapes through the mouth, and in doing so makes a plosive sound. The vocal cords do not vibrate, as a result voiceless sound is produced. Regarding its distributions, it occurs in all the positions, viz, initial, medial and final.

Initial	Medial	Final
/teremlɔt̪/ 'stick'	/mɔtkəbɔ/ 'skin'	/t̪iji:t/ 'horizon'
/tutumɔl/ 'fan'	/mettaymul/ 'milk'	/ko:t/ 'laugh'

Allophonic Variants:

/t/ has two allophones (t) and (t^h).

(t^h) voiceless unaspirated unreleased alveo-dental, sometimes occurs in the syllabic final position.

/erba:t/ 'extinguish fire' /tirpile:ɛɔt/ 'all teeth' /t̪ɔk^hote:t/ 'tree leaves'

(t) voiceless unaspirated alveo-dental stop occurs elsewhere.

/d/ is a voiced aspirated alveo-dental stop. It is articulated in the same manner as that of /t/ except that the force of exhalation is weaker and the vocal cords are made to vibrate so that voice is heard. Regarding its distributions, it occurs only in two positions i.e. initial and medial. It has no allophonic variation.

Initial	Medial
/du/ 'that distant'	/p ^h u:doʈəŋ/ 'palm tree'
/di/ 'this'	/hutk ^h doe/ 'globe'

/t^h/ is a voiceless aspirated alveo-dental stop. It is articulated in the same way as that of /t/ except for the fact that the sound is aspirated one. Regarding its distributions, it occurs only in the two positions, viz. initial and medial. It has no allophonic variation.

Initial	Medial
/t ^h oru:be/ 'frog'	/jet ^h o/ 'a sea snake'
/t ^h i: bel/ 'broom'	/mɔcot ^h aro/ 'cock'

/ʈ/ is a voiceless unaspirated retroflex stop. It is produced when the tip of the tongue is curled back in the direction of the front part of the hard palate. Vocal cords are held wide apart, as a result a voiceless sound is produced. Regarding its distributions it occurs in all the positions, viz. initial medial and final.

Initial	Medial	Final
/t̪əuɖe/ 'rat'	/ca:y̪ɔlo/ 'flower'	/a:t̪/ 'fire'
/t̪ɛle/ 'elephant'	/tan̪ɔ/ 'necklace'	/perɛ:t̪/ 'an ant'

Allophonic variants:

/t̪/ has two allophones (t̪) and (t̪').

(t̪) voiceless unaspirated retroflex stop occurs elsewhere

(t̪') voiceless unaspirated unreleased retroflex stop sometimes occurs in syllabic final position.

/t̪ɔk^hote:t̪'/ 'cloud'

/era: bat̪t̪'/ 'tail'

/d̪/ is a voiced unaspirated retroflex stop. It is articulated in the same way as that of /t̪/ except for the fact that vocal cords vibrates and the voiced sound is produced. Regarding its distributions, it occurs only in the initial and medial positions. It has no allophonic variation.

Initial	Medial
/d̥i:u/ 'run'	/p ^h a:l̥uo/ 'big wave'
/d̥u:m/ 'contipede'	/tut̥d̥i:lo/ 'island'

/t^h/ is voiceless aspirated retroflex stop. It is produced in the same way as that of /t/ except for the fact that the sound is aspirated one. Regarding its distributions, it occurs in all the positions, viz, initial, medial and final. It has no allophonic variation.

Initial	Medial	Final
/t ^h ɛbala/ 'elbow'	/t ^h ɛrcotut ^h ɔmo/ 'cap'	/tokomet ^h / 'pillow'
/t ^h imik ^h u/ 'forest'	/t ^h ɔkotəracet ^h o/ 'root of trees'	/teremit ^h / 'light'

/k/ is voiceless unaspirated velar stop. During its articulation the air passage is completely blocked by raising the back of the tongue to touch the fore part of the soft palate, the soft palate being at the same time raised so as to shut off the nose passage; the air is compressed by pressure from the lungs and when the contact of the tongue with the palate is released by lowering the tongue,

the air suddenly escapes through the mouth and in doing so makes a plosive sound. The vocal cords do not vibrate; as a result a voiceless sound is produced. Regarding its distributions, it occurs in all the positions, viz, initial, medial and final.

Initial	Medial	Final
/kɔ:lɔ/ 'eagle'	/p ^h ikku/ 'a badder fish'	/p ^h iluk/ 'a tree'
/ke:r/ 'black ant'	/totkɔwba:lɔ/ 'field'	/mɔ:rɔk/ 'an oyster'

Allophonic Variants:

/k/ has two allophonic variants (k) and (k')

(k') Voiceless unaspirated and unreleased post velar stop sometimes occurs in the syllabic final position.

/re:k'/ 'big crab' /luk'/ 'lift' /erte:k'/ 'middle portion of hunting bambo.

/k/ voiceless unaspirated velar stop occur elsewhere.

/g/ is a voiced unaspirated velar stop. It is formed exactly like that of /k/ except that the force of exhalation is weaker and the vocal cords are made to vibrate so that voiced sound is produced. Regarding its distribution it occurs only in the medial position. It has no allophonic variants.

Medial

/uetagugum/ 'flying something'

/oʈɔŋgeralottɔm/ 'uprooting trees'.

/k^h/ is a voiceless aspirated velar stop. It is articulated in the same way as that of /k/ except for the fact that the sound is an aspirated one. Regarding its distributions, it occurs only in two positions i.e. initial and medial. It has no allophonic variation.

Initial	Medial
/khi:nɔ/ 'grass'	/ʈak ^h otoʈɔm/ 'branch'
/k ^h eŋe/ 'cat'	/ercnimik ^h a/ 'bell'

Affricates

A term used in the classification of consonant sounds on the basis of their manner of articulation. It refers to a sound, produced when the air -pressure behind a complete closure in the vocal tract is gradually released, the initial release produces a plosive, but the separations, which follow, is sufficiently

slow to produce audible friction, and there is thus a fricative element in the sound also. However, the duration of friction is usually not as long as would be the case for an independent fricative sound. If it is very brief indeed the term 'affrication' is used. There are only two affricate consonant phonemes in this language- /c/ and /j/. A brief articulatory description of each one of them on the basis of place and manner criteria is given below.

/c/ is a voiceless unaspirated palatal affricate. In producing this sound, the air - passage is completely blocked by raising the soft palate and by raising the tip and blade of the tongue, air is compressed by pressure from the lungs. When the tongue is removed from the teeth ridge, the air escapes through the mouth, as a result some friction is heard. The vocal cords do not vibrate, as a result voiceless sound is produced. Regarding its distributions, it occurs in all the positions, viz. initial medial and final. It has no allophonic variants.

Initial	Medial	Final
/cokbi/ 'fins'	/urcɔ/ 'net'	/kɔtʰe:c/ 'earthen pot'
/carrolo/ 'parrot'	/ucle/ 'shirt'	/tʃɛwterbec/ 'cloud'

/j/ is a voiced unaspirated palatal affricate. It is produced exactly as */c/* except that the vocal cords are made to vibrate so that 'voice' is produced during the articulation of the sound. Regarding its distributions, it occurs only in initial and medial positions. It has no allophonic variants.

Initial	Medial
<i>/julu/</i> 'clothes'	<i>/ijo:kke/</i> 'eat'
<i>/ji:rmu/</i> 'horse'	<i>/ejire/</i> 'bad words'.

Nasals:

It is a term used in the phonetic classification of speech sounds on the basis of manner of articulation. It is a type of consonant segment, which, like a stop, is produced by a structure of complete closure; a nasal, however, unlike a stop, has no simultaneous velic closure. The air-stream, therefore, though prevented from passing through the mouth, is not dammed up; it is entirely diverted through the nose. There are four nasal consonants in this language: */m/*, */n/*, */ɲ/* and */ŋ/*. A brief articulatory description of each one of them is given below on the basis of place and manner criteria.

/m/ is a voiced bilabial nasal. During the articulation of */m/*, the two lips are brought together and the oral passage is blocked completely. The soft palate is

lowered to let the compressed air from the lungs pass through the nasal passage freely. The tongue is held in the neutral position. When the lips are opened, some portion of the compressed air also passes through the mouth, leading to a weak plosion. The vocal cords remain vibrating, as result voiced sound is produced. Regarding its distributions, it occurs in all the positions, viz., initial, medial and final.

Initial	Medial	Final
/mino/ 'potato'	/jemo/ 'a shark'	/du:m/ 'centipede'
/mɔcco/ 'hen'	/tɔymo/ 'grasshopper'	/ta:tom/ 'ground'

Allophonic Variants:

/m/ has two allophones: (m) and (m')

(m') a voiced unreleased bilabial nasal, sometimes occur in the final syllabic position.

/miyaytutculoʝm/ 'tamarind tree' /okɔ:t^həm/ 'sneezes'

(m) a voiced bilabial nasals occur elsewhere.

/n/ is voiced alveolar nasal consonant. It is formed when the mouth-passage is completely blocked by raising the tip of the tongue to touch the teeth-ridge.

The soft palate is lowered to that, when air is emitted by pressure from the lungs, it passes out through the nose; the vocal cords are made to vibrate to that 'voice' is produced. Regarding its distribution it occurs in all the positions, viz, initial, medial and final.

Initial	Medial	Final
/nyure:/ 'fish'	/rɛ:nmu/ 'iron'	/it ^h u:n/ 'drop'
/nip ^h o/ 'small mosquito'	/rɛ:nmo/ 'tuberculosis'	/caecɔn/ 'hammer'.

Allophonic variants:

It has two allophones (n') and (n).

(n') voiced alveolar unreleased nasal consonant, sometimes occur in the syllabic final position.

/kata:n'/ 'stars'

/pərain'/

'water

shower'

(n) voiced alveolar nasal occur elsewhere.

/ɲ/ is a voiced palatal nasal. This sound is produced by the hard palate and front of the tongue. The breath stream is interrupted at some point in the oral

cavity while being allowed to enter the nose and create resonance. The soft palate is lowered so that the air passes through the nose. The vocal cords are made to vibrate; as a result 'voice' is produced. Regarding its distributions, it occurs in all the positions, viz, initial, medial and final. It has no allophonic variants.

Initial	Medial	Final
/ɲo:co/ 'house'	/ibe:liɲe/ 'cut'	/ɔɲ/ 'tree'
/ɲyo:/ 'camp'	/ra:tkɔlɔɲo/ 'he slipped'	/ɲu:ɲ/ 'dew'

/ŋ/ is a voiced velar nasal. It is produced when the mouth-passage is completely blocked by raising the back of the tongue to touch the fore part of the soft palate, the soft palate is in its lowered position, so that when the air is emitted by pressure from the lungs it passes through the nose: the vocal cords are made to vibrate, so as a result 'voice' is produced. Regarding its distributions, it occurs in all the positions, viz. initial, medial and final.

Initial	Medial	Final
/ɲeɕen/ 'dark'	/ɕoŋk ^h u:/ 'glass'	/bu:ruŋ/ 'hill'
/ɲu:ɲ/ 'dew'	/ke:ɲe/ 'cat house'	/ta:rboriŋ/ 'aeroplane'

Allophonic variants:

It has two allophones (ŋ') and (ŋ)

(ŋ') a voiced velar nasal, sometimes occurs in the syllabic final position

/tɔylɔcoŋ'/ 'deer'

/miɛtɛŋ'/

'darkness'

/ŋ/ voiced velar nasal occur elsewhere.

Liquids:

It is a term used by the phonetician in the classification of speech sounds on the basis of manner of articulation. It is articulated by the tip of the tongue touching the teeth-ridge in such a way that though there is a complete closure in the middle of the mouth, yet a passage for the air is left on one or both sides of the tongue; the soft palate is in its raised position; the vocal cords are made to vibrate so that 'voice' is produced. There are two liquid consonants in this language: /l/ and /r/

/l/ is voiced alveolar lateral. It is produce by stricture of complete closure in the centre of the vocal tract, so that there is lateral passage of the air-stream, round the side or sides of the obstruction. The soft palate is raised to sheet off

the nasal passage. The sides of the tongue are lowered so that the air is free to escape along the sides of the tongue without any friction. The vocal cords are made to vibrate so that 'voice' is produced. Regarding its distributions it occurs in all the positions, viz. initial, medial and final.

Initial	Medial	Final
/le:le/ 'cradle'	/bi:lu/ 'ship'	/t ^h umel/ 'honey'
li t ^h emo/ 'water frog'	/bolmo/ 'leech'	/t ^h a:l/ 'gold'

/r/ is voiced alveolar trill. It is produced from a stricture of intermittent closure. The tip of the tongue is loosely held near the teeth ridge and set in vibration by the action of air stream. The soft palate is raised to close the nasal passage. The vocal cords are made to vibrate as a result 'voice' is produced. Regarding its distributions it occurs in all the positions, viz., initial, medial and final.

Initial	Medial	Final
/rɛ:p ^h e/ 'food/rice'	/carrolo/ 'parrot'	/ke:r/ 'snore'
/rɛ:nmu/ 'iron'	/tereŋ/ 'whole'	/i:r/ 'wave'

Fricative:

It is a term used in the phonetic classification of consonant sounds on the basis of their manner of articulation. It is articulated with a stricture of close approximation; that is the two articulators are brought so close to each other that the gap between them is very narrow with audible frictions. There are three fricative found in this language: /s/, /ʃ/, and /h/

/s/ is voiceless alveolar fricative. It is articulated by the blade of the tongue against the teeth - ridge, the front of the tongue being at the same time somewhat raised in the direction of the hard palate. The teeth are close together; the sound cannot be pronounced with the mouth wide open. The space between the blade of the tongue and the teeth-ridge is extremely narrow. The soft palate is in its raised position, and the vocal cords do not vibrate. Regarding its distribution, it occurs only in two positions, viz. initial and medial.

Initial	Medial
/su:bi/ 'snake'	/ɔ:rsu:bi/ 'black sea snake'
/si:ro/ 'ocean'	/nuttise/ 'bed sheet'

/s/ is voiceless palatal fricative. It is articulated by the tip and blade of the tongue against the hind part of the teeth-ridge, the whole of the main body of the tongue being simultaneously held in a raised position. The teeth are close or fairly close together; the sound cannot be properly pronounced with the mouth wide open. The space between the blade of the tongue and the teeth ridge is narrow, though wider than for /s/. On the other hand the air channel in the region of the palate is narrower than in case of /s/. The soft palate is in its raised position, and the vocal cords are made to vibrate. Regarding its distribution, it occurs in all the position, viz., initial, medial, and final.

Initial	Medial	Final
/ʃurum/ 'a crab'	/cerʃo/ 'sneeze'	/adiʃ/ 'god'
/ʃotta:ymuniyo/ 'people'	/uʃuy/ 'deep'	/adiʃ/ 'god'

/h/ is a voiceless post velar fricative. In the articulation of this sound, the tongue remains in the neutral or relaxed position leaving the oral cavity wide open. In fact the mouth is held in vowel position and the air stream in the lungs passes through the wide open glottis and the soft palate is raised to close the nasal passage. The vocal cords do not vibrate. Regarding its distribution, it occurs only in the initial position.

Initial	
/hitkət ^h a/ 'circle'	/həleteracol/ 'light'

Semi-Vowels

They are defined as independent vowel-glides in which the speech - organs start by forming a weakly articulated case or fairly close vowel and immediately more to another sound of equal or greater prominence; the initial vowel position is not held for any appreciable time. It is the rapid gliding nature of these sounds, combined with the use of rather weak force of exhalation, which renders them consonantal. There are two semi-vowels in this language: /w/ and /y/.

/w/ is a voiced labial semi-vowel. In articulation of /w/ the lips are closely rounded; there is considerable raising of the back of the tongue in the direction of the soft palate; the soft palate is in its raised position; the vocal cords are made to vibrate so that voice is heard. Regarding its distributions, it occurs in all the positions; viz. initial, medial and final.

Initial	Medial	Final
/wera:kuikɔm/ 'smokes cigrette'	/kolɛwbe/ 'laugh'	/biyu:w/ 'light'
/weta:rk ^h aidueson/ 'listening to radio'	/kɔwbu/ 'umbrella'	/ɖula:w/ 'ghost'

/y/ is a voiced palatal semi-vowel. In articulation of this sound the speech-organs start at, or near the position of short /i/ and immediately leave this for some other sound of equal or greater prominence. The front part of the tongue is raised rather high in the direction of the hard plate, the lips are spread; the soft palate is in its raised position; the vocal cords are made to vibrate, so that voice is heard. Regarding its distributions, it occurs in all the positions, viz, initial, medial and final.

Initial	Medial	Final
/yuʃu/ 'fresh water snake'	/ma:ye/ 'father'	/birey/ 'a bat'
/yele/ 'return'	/ca:yɬɔlo/ 'flower'	/ullu:y/ 'whistle'

The Phonetic variation chart and Phonemic Distribution chart of given in the following pages respectively.

Phonetic Variation Chart: Consonants

Place of Articulation

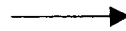

Manner of Articulation	Bilabial		Alveo Dental		Alveolar		Retroflex		Palatal		Velar		Post Velar	
	Vl	Vd	Vl	Vd	Vl	Vd	Vl	Vd	Vl	Vd	Vl	Vd	Vl	Vd
S Plosive	pp ^l	b	tt ^l	d			ʈʈ ^l	ɖ			kk ^l	g		
T Unasp														
O	p ^h		t ^h				t ^h				k ^h			
P Asp														
Affricates									c	j				
Nasals		mm ^l				nn ^l				ɲ		ŋŋ ^l		
Trill						r								
Fricative					s				ʃ					h
Lateral						l								
Approximants		w								y				

Phonemes Distribution Chart: Consonants

	Initial	Medial	Final
p	✓	✓	✓
b	✓	✓	X
p ^h	✓	✓	X
t	✓	✓	✓
d	✓	✓	X
t ^h	✓	✓	X
ɾ	✓	✓	✓
d̥	✓	✓	X
t ^h	✓	✓	✓
k	✓	✓	✓
g	X	✓	X
k ^h	✓	✓	X
ç	✓	✓	✓
j	✓	✓	X
s	✓	✓	X
ʃ	✓	✓	✓
h	✓	X	X
m	✓	✓	✓
n	✓	✓	✓
ɲ	✓	✓	✓
ŋ	✓	✓	✓
l	✓	✓	✓
r	✓	✓	✓
w	✓	✓	✓
y	✓	✓	✓

3.2.2 Contrast of minimal and sub-minimal pairs

Voiceless Vs Voiced

[p/b]

/pɔ:r/	'bamboo'	/perɛ:t/	'an ant'
/bɔ:r/	'wind'	/bere:t/	'a frog'

[t/d]

/t̪i:/	'place'
/di/	'this'

[c/j]

/celmo/	'a flower'	/etbocokke/	'cut'
/jelmo/	'a worm'	/etbojokke/	'sharpen'

Aspirated Vs Unaspirated

[p/p^h]

/puro:/	'a stone'
/p ^h uro:/	'owl'

[t/t^h]

/erba:tte/	'put off light'
/erba:tt ^h e/	'wing of fish'

[t̪/t̪^h]

/t̪ume:l/	'bee hive'
/t̪ ^h ume:l/	'honey'

[k/k^h]

/ki:no/	'honey'
/k ^h i:no/	'grass'

Nasals:

[m/ŋ]

/myo:/	‘rock’
/ŋyo:/	‘camp’

[m/ŋ]

/ɔ:m/	‘a tree’
/ɔ:ŋ/	‘jungle plantain tree’

[n/ŋ]

/niyo/	‘jaw’
/ŋiyo/	‘they’

[n/ŋ]

/p ^h on/	‘a big see crab’	/niyo:wbe/	‘they’
/p ^h oŋ/	‘cave’	/ŋiyo:be/	‘you’

Alveolar

[r/l]

/bo:r/	‘wind’	/bo:r/	‘thorny creeper’
/bo:l/	‘tree’	/bo:l/	‘sweet water snake’

3.2.3 Consonant Sequence

Andamanese language permits only a sequence of two consonants.

Distribution of consonant sequence.

Word initial consonant sequence are not found in this language with exception of ηy -. This language is also marked by the absence of word final consonant sequence. However CC sequence in word medial position is found in abundance.

Possible word – initial consonant sequence

Cluster Starting with	Example	Gloss
ηy -	$\eta yo:$	camp
ηy -	$/\eta yu:wre/$	fish

Possible word-medial consonant sequences are found in abundance in word-medial position. The table below gives the list of consonant sequences occurring in word-medial position.

Sequence Starting with	Example	Gloss
-pb-	$\tau o:pbe$	bath
-pt-	$jire:pt o:p$	wasp
-pr-	$o:pr o$	window
-pl-	Ontoplo	one
-tb-	$etbo:cokke$	sharpen
- τp^h -	$to:\tau p^h olo$	beach
-td-	$tutdj:lo$	island
-tk-	$etk o wbo$	bark of tree
-- tk^h -	$hutk^h udoe$	globe
-tc-	Etcow	fruit of tree

-tm-	Celetmɔ	bread
-ta-	əbɪlɪk ^h utɲio	/rayer room/temple
-tr-	etrak ^h o	edge of bow
-tl-	ɲutli:p	skin your
-tb-	kɔtɔbe:lo	a sea snake
-tp ^h -	kɔtɔp ^h e:c	eastern pat
-tt-	kɔ:tɔtco	white ant hive
-td-	a:tɔɔ:p	fire wood chips
-tk ^h -	-itk ^h emo	water frog
-tc-	miyaytuɔculojomi	tamarind tree
-tm-	kɔtmɔra:y	white art
-tl-	a:tɔluru	fire
-kb-	cokbi:	fins
-kt-	Ektertu:t	push
-kt-	ektene	pull
-kk ^h -	bilikk ^h	spider
-kc-	ertekɔ:kɔ	middle one
-kn-	ekno:tɔte	pero
-kp-	ekɲe:le	puruse
-kɲ-	ekɲɔ:le	hoè
-kr-	krinkɔ:so	strait island
-kl-	iklɔ:tɔte	insert
-k ^h d-	hirk ^h doe	round
-ck ^h	Usumulcaytarck ^h o	keeping something on top
-cm-	k ^h ulicmo	a thorny crepper
-cl-	djɪ:dettecla:w	jungle ghost
-sd-	t ^h e:sdu	my
-sy-	asyu:wbi	who
-mb-	emboya	marriage
-mɔ-	cɔmɔɔm	suparee tree
-mk ^h -	ɲɔmk ^h ɔɲ	your arbet

-nt-	caetəteituntəplə	One packet
-nt ^h	utu:nt ^h iritalille	Swinging her children
-nɿ-	pərointəŋ	bread
-ng-	oɿəŋgeralottəm	uprooting trees
-nd-	undujiro:l	shivering
-nk-	ko:nkuro	full hand
-nc-	t ^h hi:taŋəroɿt ^h uncuimo	house lock
-nm-	rɛ:nmu	iron
-nr-	ŋənrə:no	your ankle
-ŋt-	ertə:ŋtutke	thorn in branch
-ŋt -	tə:ŋtut ^h ijut	shade of trees
-ŋk -	t ^h əŋkuro	my palm
-ŋk ^h -	təŋk ^h u	glass
-ŋm-	ɛŋməcom	scratching
-ŋl-	uɿə:ŋleuramet ^h um	putting soil between trees
-ŋb-	tebolbe	run away
-lt-	termoltərcit ^h allo	Zig-zag line
-ld-	pa:lduwo	big wave
-lm-	ji:lmo	land tortoise
lŋ-	tɛlŋe	mosquito
-rp-	t ^h ɛrpili	my tooth
-rb-	t ^h ɛrbu:jum	ear ring
-rp ^h	t ^h ɛrp ^h a:ra	parting of hair
-rt-	pirta:rɛycopoba:ləŋ	rainbow
-rɿ-	k ^h idi:rɿəŋ'	coconut tree
-rɿh	penot ^h isort ^h i	cot
-rd	t ^h itərdit ^h	gap in the wall
-rk-	t ^h ɛrkət ^h ojum	nose ring
-rk ^h -	k ^h ɛŋet ^h irk ^h uru	big cat
-rc	t ^h ɛrcotut ^h əmo	cap

-rj	t ^h ɛjuk ^h ubɛc	my moustache
-rs-	ɔ:rsu:bi	a black sea snake
-rm-	t ^h ɛrmine	My stomach
-rn-	ka:mɔ	Type of potato
-rɲ-	ɛrɲɔbo:rɔɲ	humming
-rŋ-	ɛrŋo:tra	twinkling
-rl-	t ^h ɛrlɔt	my stick
-rw-	ərwə	boat
-wb-	nɔwba:ɔ	water snake
-wp ^h -	ɛɛ:w:p ^h o	thick
-wt-	tɔwta:mme	front portion of hunting bamboo
-wɬ-	ɛɛ:wɬe:t	short one
-wɖ-	tɔwɖe	rat
-wc-	diyu:wcoɲ	A shark
-ws-	liyu:wsi	surmai fish
-wm-	biyu:wmoy	torch
-wn-	ɲawnobɔ	you sit down
-wr-	ɛra:wɔ	tail
-wl-	kara:wlu	snail
-yp-	kɛyp	red mud used to decorate
-yb-	ca:ybe	what
-up ^h -	caba:yp ^h e	job
-yk ^h -	ca:yk ^h ute	why
-yc-	ɛycorɔ:k	ladder
-yl-	tɔylaɔɲ	deer

Heterogeneous Consonants Sequence

C ₂ →	P	b	p _h	t	d	t ^h	ṭ	ḍ	t ^h	k	g	k _h	c	j	s	ʃ	h	m	n	ɲ	ŋ	r	l	w	y	
C ₁ ↓																										
p		✓					✓																✓	✓		
p _h																										
t		✓	✓				✓	✓		✓		✓	✓						✓	✓	✓		✓	✓		
d																										
t ^h																										
ṭ		✓	✓	✓	✓					✓		✓	✓						✓					✓		
ḍ																										
t ^h																										
k		✓		✓			✓					✓	✓							✓	✓	✓	✓	✓		
g																										
k _h					✓								✓													
c													✓						✓				✓			
j																										
s								✓																		✓
ʃ																										
h																										
m		✓					✓					✓														
n					✓		✓	✓	✓		✓		✓						✓				✓			
ɲ																										
ŋ				✓			✓			✓		✓							✓				✓			
l		✓		✓				✓											✓			✓	✓			
r	✓	✓	✓	✓			✓	✓	✓	✓		✓	✓	✓	✓	✓	✓		✓	✓	✓	✓	✓	✓	✓	
w		✓	✓	✓			✓	✓					✓	✓		✓			✓	✓		✓	✓		✓	
y	✓	✓	✓									✓	✓										✓	✓		

Geminate Consonants:

Geminate consonants are nothing but double consonants phonetically. A double consonant is one whose duration extends over two syllables (Abercombie, 1967, p. 82) i.e., there is always a syllable break between the two consonants.

Geminated consonant Clusters

-tt-	ka:yttɔ/ etto:p/ ettay	jack fruit tree/ cover/ blood
-tt-	loyɛtto	pumpkin
-kk-	mijo:kke	eat
-cc-	mɔcco	hen
-ss-	issu:ye	burn
-nn-	inno	water
-mm-	purummomyo:/ emmulu	big rock / egg
-ŋŋ-	rɛ:ŋŋɔ	pebbles
-ŋŋ-	ɪŋŋarɔ:wlam/ ibe:liŋŋe	shower/ cut, saw
-ll-	Kollo	eagle
-rr-	carrolo	parrot

From the above table we can say that all voiceless unaspirated stops found in this language, namely /t/, /t̪/, /c/ and /k/ except /p/ have geminated consonant sequence. Secondly nasal consonants found in this language i.e. /m/, /n/, /ŋ/ and /ŋ/ are geminated one in this language. Thirdly liquid /l/ and /r/ also occur as geminates in this language.

Geminated Consonant Cluster

$C_2 \rightarrow$	p	b	p^h	t	d	t^h	t	d	t^h	k	g	k^h	c	j	s	ʃ	h	m	n	ɲ	ŋ	r	l	w	y
$C_1 \downarrow$																									
p																									
b																									
p^h																									
t				✓																					
d																									
t^h																									
t							✓																		
d																									
t^h																									
k										✓															
g																									
k^h																									
c													✓												
j																									
s															✓										
ʃ																									
h																									
m																			✓						
n																				✓					
ɲ																					✓				
ŋ																						✓			
r																							✓		
l																									
w																									
y																									

3.3 Vowels

Vowels are sounds articulated without a complete closure in the mouth or a degree of narrowing which would produce audible friction; the air escapes evenly over the centre of tongue.

In Andamanese language, eight vowels phonemes have been recognised from the data. The vowel phonemic chart is given in the next page and each one of them is described on the basis of articulatory terms.

3.3.1 Descriptions and distribution of each vowel phonemes

/i/: is a short high front unrounded vowel. It is articulated when the front part of the tongue is raised in the direction of hard palate, to an almost close position. The lips are spread while articulating. It occurs in all the three positions.

Initial	Medial	Final
<i>/i/i/</i> 'urine'	<i>/iɖit/</i> 'hole'	<i>/bei/</i> 'bottle'
<i>/inora/</i> 'bucket'	<i>/lim/</i> 'area stone'	<i>/li:p^{hi}/</i> 'a tree'

/e/ is a short mid-front unrounded vowel. This vowel is produced by raising the front part of the tongue towards the palate but not as high as */i/*. The lips are spread. Regarding its distribution, it occurs in all the positions, viz., initial, medial and final.

Phonemic Chart: Vowels

Part of Tongue →	FRONT		CENTRAL		BACK	
Height of Tongue ↓	Unrounded	Rounded	Unrounded	Rounded	Unrounded	Rounded
High	i					u
Lower High						
Higher Mid	e					o
Mean Mid			ə			
Lower Mid	ɛ					ɔ
Higher Mid						
Low					a	

Initial	Medial	Final
/ettay/'blood'	/jero/'papaya tree'	cayo:ne'oil'
/etcol/ 'gill of the fish	/cel/'water falls	di:de/'noon'

/ə/ is a central unrounded vowel.. During the production of this vowel the central part of the tongue is raised. The tongue lies in the neutral position. The lips stretch a little less than the shape for /e/ phoneme. Regarding the distributions it occurs in only two positions, viz. initial and medial.

Initial	Medial
/əra/'pig'	/təudɛ/'rat
/əra:tubulu/ 'Lame'	/mɔtkəbo/ 'slan'

/ɛ/ is a short unrounded lower mid front vowel. During the production of this vowel, the front part of tongue is raised towards the hard palate. Regarding the distributions, it occurs in all the positions viz., initial, medial and final.

Initial	Medial	Final
/ɛy/ 'vomit'	tɛle/ 'elephant'	/berɛ/ 'parshaw fish'
/ɛt ^h a,rɔ/ 'male'	tɛlebo/ 'dandush fish'	/a:/ɛ/ 'lightning'

/a/ is a short unrounded low back vowel. This vowel is produced by the central part of the tongue. The tongue remains in the neutral position but lowering of the lower jaw makes it an open vowel.. The lips are open and spread a little; neither round nor spread totally. Regarding its distributions, it occurs in all the positions; viz., initial, medial and final.

Initial	Medial	Final
/aro:/ 'pharrow fish'	/Caecɔn/ 'hammer'	Kata/ 'daughter'
ara:/ɛ:p ^h a/ 'window'	/po:ttale/ 'an arrow'	/p ^h atka/ 'crow'

/ɔ/ is a short rounded lower-mid back vowel. In the production of this sound; the back part of the tongue is raised towards the soft palate. The tip of the tongue remains unraised and is retracted to a certain degree so as to enable the back part of the tongue to rise to the required height. The lips are rounded.

Regarding its distributions, it occurs in all the positions, viz, initial, medial and final.

Initial	Medial	Final
/ɔ/ɔ/ 'axe'	/mɔtkɔbɔ/ 'skin'	/t ^h a:tɔ/ 'house'
/ɔtkɔrɔ/ 'net'	/ca:ytɔlo/ 'flower'	/mi:nɔ/ 'type of potato'

/o/ is a short rounded mid back vowel. While producing this sound the back portion of the tongue is raised. The lips are protruded and rounded. The soft palate is raised and the vocal cords are vibrating. It occurs in all the positions, viz., initial, medial and final.

Initial	Medial	Final
/ɔtkatta/ 'short'	tɔytccɔŋ ^l 'deer'	/kɔllo/ 'Eagle'
/ɔttɔtɔya/ 'watch'	/cowba/ 'asmall fish'	tɔ:ro/ 'Sand'

/u/ is a short rounded high back vowel. While producing this vowel, the back portion of the tongue is raised as high as possible towards the soft palate, but the tip of the tongue is not raised. The lips are rounded and

protruded. The soft palate is raised and vocal cords are vibrating. Regarding its distributions, it occurs in all the positions viz, initial, medial, and final.

Initial	Medial	Final
/ulluk ^h u/ ‘cobra’	/i.mulu/ ‘egg’	/julu/ ‘dress’
/uluwc:/ ‘fountain’	/sulu/ ‘type of print’	/i:ttu/ ‘a fish’

3.3.2 Minimal and sub minimal pairs: Vowels:

/mimi/ ‘mother’	/mime/ ‘brother’s wife’
/pi:r/ ‘a cane’	/pu:r/ ‘sound made by clapping hand with thigh’
/pi:r/ ‘a cane’	/pɔ:r/ ‘bamboo’
/rɛ:nmu/ ‘iron’	rɛ:nmo/ ‘tuberculosis’
/ɲya/ ‘have (it)’	/ɲyo:/ ‘camp’
/p ^h oro:t/ ‘pharsnaw fish’	/p ^h oro:t/ ‘a black sea worm’
/kal/ ‘a small sea crab’	mɔ:l/ ‘shangar fish’
/cɔ:y/ ‘mother’s matter’	/co:y/ ‘a tree’

/ara:/ 'pig'	/aro:/ 'phassaw fish'
/ekka: dum/ 'thin'	ekko;dum/ 'thick'
/ettɔ:le/ 'decorate'	ettu:le/ 'beat'
/di/ 'this'	/du/ 'that (distant)'
/di/ 'this'	/do/ 'this (proximate)'
/du/ 'that (distant)'	/da/ 'this'
/pu:r/ 'Sound made by clapping hands with thigh'	/pɔ:r/ 'bamboo'
/bo:l/ 'thorny creeper'	bɔ:l/ 'tree'
/a:t/ 'fire'	/ɔ:t/ 'a tree'
/aro:/ 'pasrhaw fish'	/ara:/ 'pig'
mu:r/ 'foam'	/ma:r/ 'a fish'
tutumol/ 'mosqueto net'	tutumɔl/ 'fan'
/esore: kke/ 'sing'	/ssoro:kke/ 'fish'

3.3.3 Phonetic Variation

Nasalisation: In the normal or oral articulation of vowels the soft palate is raised so that it blocks the nasal passage. If however, the soft palate is

lowered, the air can pass through the nose as well as the mouth, and the vowels so articulated are nasalised. Nasalisation in Andamanese is not phonemic. But as the data show, one does find some vowels in Andamanese with full nasalisation, which may be due to the influence of nasalised phonemic vowels in Port Blair Hindi. Data also show that some vowels sometimes get nasalised, if it is preceded or followed by nasal sounds.

/t ^h oŋkurɔ/	‘my palm’
/hutk ^h udoe/	‘globe’
/mɔcco/	‘hen’
/cɛletmɔ/	‘bread’
/t ^h itemɔ/	‘pen / pencil’
/təra:mluk ^h imi/	‘balance’

3.3.4 Phonemic Variation:

Vowel length in Andamanese language is phonemic. The contrast of vowel length is illustrated by the following:

[i/i:]	/mirit/ ‘a fish’	/miri:t/ ‘pigeon’
	/ti/ ‘g’	/ti:/ place’

[e/e:]	/tercɪ/ 'whole'	/tere:ŋ/ 'whole fish'
	/le/ 'smoke'	/le:/ 'land crab'
	/dolemo/ 'squirrel'	/dole:mo/ 'big lyaid'
[ɛ/ɛ:]		
	/kolɛwbe/ 'length'	/ɛlɛ:wbe/ 'small'
[o/o:]	/bol/ 'rope'	/bl:l/
[ɔ/ɔ:]	/tɔw/ 'a tree'	/tɔ:w/ 'sky'
[a/a:]	/ta/ 'hands'	/ta:/ 'sound made by clapping'

3.3.4. Distribution of /i:/, /e:/, /ɛ:/, /a:/, /o:/ /ɔ:/ and /u:/

/i:/ Regarding its distribution, it occurs in all the positions, viz, initial, medial and final.

Initial	Medial	Final
/:mulu/ 'egg'	/ni:p ^h o/ 'small mosquito'	/cokbi:/ 'fins'
/i:ŋno/ 'water'	/ji:rmu/ 'house'	/ti:/ 'place'

/e:/ Regarding its distributions of /e:/, it occurs in all the positions, viz. initial, medial and final.

Initial	Medial	Final
/e:toe/ 'bone'	/te:ɔ/ 'crocodile'	/uluwe:/ 'fountain'
	/ce:yo/ 'knife'	/sure:/ 'a fresh water snake'

/ɛ:/ Regarding its distribution, it occurs in only one position viz., medial.

Medial

/bɛ:mo/ 'might angle'

/le:c'/ 'an arrow'

/a:/ It occurs in all the positions, viz., initial, medial and final

Initial	Medial	Final
/a:t/ 'fine'	ta:l/ 'gold'	/bowa:/ 'earth'

/a:le/ 'light'	/p ^h :l/ 'wani'	/kɔca: / 'cycle'
----------------	----------------------------	------------------

/o:/ It occurs in all the positions, viz, initial, medial and final

Initial	Medial
/o:prɔ/ 'window'	/lujiro:yəm/ 'dance'
/o:kra/ 'type of fish'	/bo:t ^h o/ 'cyclone'

/ɔ/ It occurs in all the positions, viz, initial, medial and final

Initial	Medial	Final
/ɔ:m/ 'tree'	/tɔ:w/ 'sky'	/urɔ:/ 'an arrow'
/ɔtkɔmɔ/ 'net'	/kɔ:lɔ/ 'eagle'	

/u/ It occurs only in two pose i.e. medial and Final

Medial	Final
/mu:r/ 'foam'	/p ^h u:/ 'cow dung'
/du:llɔ/ 'moon'	

Phonemes Distribution Chart: Vowel

Vowel	Initial	Medial	Final
i	✓	✓	✓
i:	✓	✓	✓
e	✓	✓	✓
e:	✓	✓	✓
ə	✓	✓	✓
ɛ	✓	✓	✓
ɛ:	X	✓	X
a	✓	✓	✓
a:	✓	✓	✓
ɔ	✓	✓	✓
ɔ:	✓	✓	✓
o	✓	✓	✓
o:	✓	✓	✓
u	✓	✓	✓
u:	X	✓	✓

3.3.5 Diphthongs:

A diphthong is a vowel sound consisting of a deliberate i.e. intentional glide, the organs of speech starting in the position of one vowel and immediately moving in the direction of another vowel. A diphthong, moreover, consists of single syllable – that is the vowel glide must be performed with a single impulse of the breath. (Peter Mac Carthy, English Pronunciation), the analysis of data show following diphthongs in Andamanese language.

-ei	/caetəʔei/	‘packet’
-iu-	/corɔlotirjiuk ^h u./	
-ei-	/caetəʔeicɔp ^h e/	‘many packet’
-ui	/k ^h əleʔmorasui/	‘makes chappati’
-ui-	/ʔ ^h i:taŋɔroiotuncuimo/	‘house lock’
-ei	/bei/	‘bottle’
-ɛi-	/t ^h ɛi/	‘cooking utensils’
-ɔi-	/re:mucɔtin/	
-ai-	/pəroinʔoŋ/	‘bread’

-ai-	/pərain/	'water shower'
-ui-	/wera: kuikəm/	'smokes cigarettes'
-ai-	/weta:rk ^h aidueson/	'listening to radio'
-oi-	/ət ^h ireniʃietəra:ncəroi/	'slipping'

iu	-	1
ei	-	3
ɛi	-	1
ai	-	2
ɔi	-	1
oi	-	2
ui	-	3

Figure

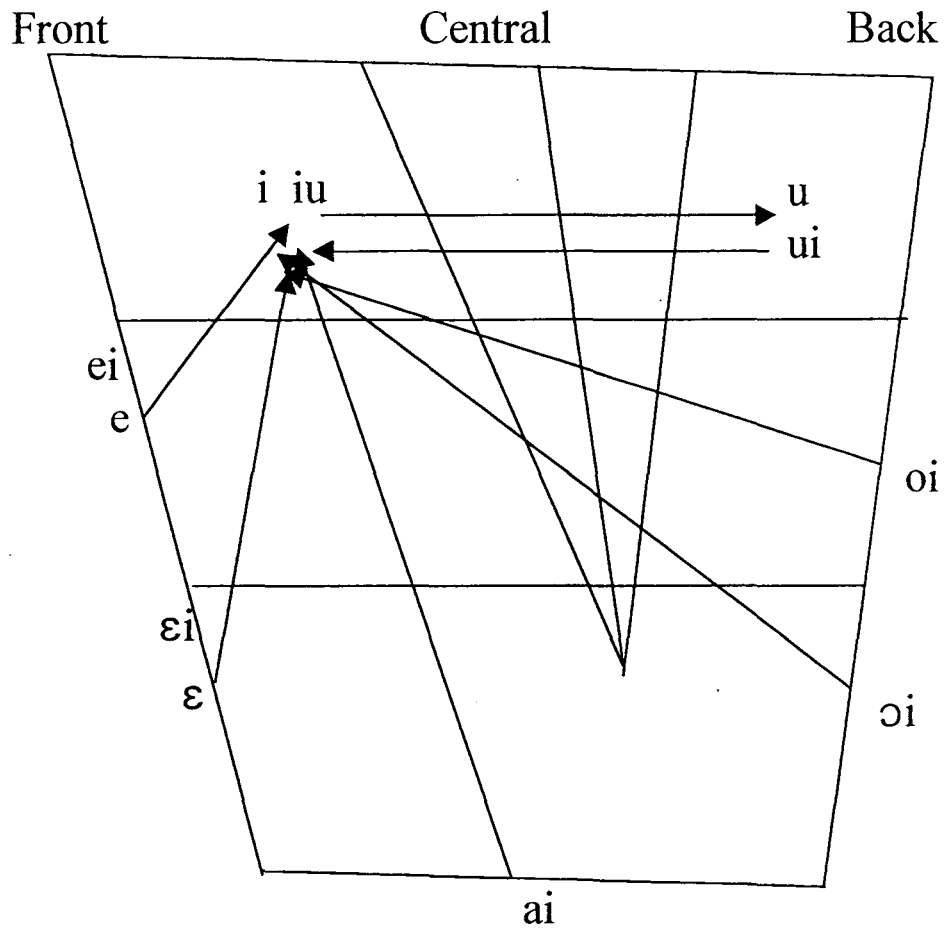

Initial vowel of a diphthongs may start with any four points on the vertical axis, close, half –close, half open and open but the diphthong finally, as the data show, ends with front high vowel (i) except in one instance in which the diphthong ends with back high vowel (u)

3.4 Syllabic structure

Syllable may be defined as a unit of pronunciation typically larger than a single sound and smaller than word. (David Crystal, 1980, p.342. A first dictionary of linguistics and phonetics). The notion of a syllable is very real to native speakers as it takes care of the rhythm of the language.

As far as the language under study is concerned the syllables range from one to seven. Further, the language is dominated by trisyllabic and tetrasyllabic word. The syllable are further classified into open and closed. A syllable, which is asserted by a consonant, is said to be a closed syllable, and one which has no asserting consonant is said to be an open syllable. (David Abercrombei, 1980, p. 42. Elements of General phonetics).

Monosyllable

Open

CV	/bo/	'an oyster'
CV	/ce/	'thorn'
CV	/jo/	'song'
CV	/ko/	'bow'
CV	/le:/	'smoke'
CV	/p ^h u:/	'cow dung'

CV	/di/	'this'
CV	/da/	'this proximate'
CV	/du/	'that distant'
CV	/ɬa:/	'sound made by clapping hands'
CV	/ɬi:/	'place'
CCV	/ɲyo:/	'camp'
CCV	/ɲya/	'have it'

Close

VC	/i:r/	'wave'
VC	/ɛy/	'Vomit'
VC	/ɔɲ/	'a jungle plantain tree'
VC	/ɔ:ɬ/	'a bat'
VC	/ɔ:m/	'a tree'
VC	/a:ɬ/	'fire'
CVC	/pɔ:r/	'bamboo'
CVC	/pe:c/	'utensils'
CVC	/pi:r/	'a cane'
CVC	/bi:p/	'dust'
CVC	/bol/	'rope'
CVC	/p ^h ɛc/	'pot'

CVC	/p ^h a:l/	'wave'
CVC	/p ^h on/	'cave'
CVC	/tɔ:p/	'bath'
CVC	/tɑ:l/	'gold'
CVC	/tɔ:w/	'sky'
CVC	/dʊ:m/	'Centipedes'
CVC	/dʊp/	'jingham tree'
CVC	/ceɪ/	'water falls'
CVC	/ke:r/	'snore'
CVC	/ko:t/	'laugh'
CVC	/su:p/	'basket'
CVC	/myo/	'rock'
CVC	/ma:r/	'a fish'
CVC	/mu:r/	'foam'
CVC	/lɛc/	'arrow'
CVC	/lɛ:c/	'weapon to kill sheep'
CVC	/lim/	'a sea stone'
CVC	/la:w/	'outsider, ghost'
CVC	/lo:l/	'there'
CVC	/rɛ:k/	'big crab'

Bisyllabic

Open

CVV	/di:u/	'sun'
CVV	/co:a/	'type of fish'
CVV	/ke:o/	'small crab'
CVV	/bei/	'bottle'
CVV	/t̪e:ɔ/	'crocodile'
CVV	/t̪ ^h ei/	'cooking utensils'
CVV	/ɲeɔ/	'house'
VCV	/ili/	'urine'
VCV	/əra/	'pig'
VCV	/uro:/	'an arrow'
CVCV	/t̪ ^h a:to/	'house'
CVCV	/t̪ ^h ɛ:co/	'my head'
CVCV	/d̪l:de/	'moon'
CVCV	/ce:yo/	'knife'
CVCV	/julu/	'clothes'
CVCV	/je:t̪ ^h o/	'a sea snake'
CVCV	/jemo/	'a shark'
CVCV	/jero/	'papaya tree'

Bisyllabic

Open

CVV	/di:u/	'sun'
CVV	/coa:/	'type of fish'
CVV	/ke:o/	'small crab'
CVV	/bei/	'bottle'
CVV	/te:o/	'crocodile'
CVV	/t ^h ei/	'cooking utensils'
CVV	/peo/	'house'
VCV	/ili/	'urine'
VCV	/era/	'pig'
VCV	/uro:/	'an arrow'
CVCV	/t ^h a:to/	'house'
CVCV	/t ^h ε:co/	'my head'
CVCV	/dɪ:de/	'moon'
CVCV	/ce:yo/	'knife'
CVCV	/julu/	'clothes'
CVCV	/je:t ^h o/	'a sea snake'
CVCV	/jemo/	'a shark'
CVCV	/jero/	'papaya tree'

CVCV	/jubu/	'fly'
CVCV	/ka:kɔ/	'banana tree'
CVCV	/kaɾa/	'daughter'
CVCV	/kɔ:lɔ/	'eagle'
CVCV	/kɔca:/	'cycle'
CVCV	/k ^h i:no/	'grass'
CVCV	/k ^h ɛpe:/	'eat'
CVCV	/su:bi/	'snake'
CVCV	/si:ro/	'ocean'
CVCV	/sa:re/	'sea'
CVCV	/sulu/	'types of fruit'
CVCV	/mino/	'potato'
CVCV	/ma:ye/	'father'
CVCV	/ma:rɔ/	'honey bee'
CVCV	/ni:p ^h o/	'small mosquito'
CVCV	/ɲo:co/	'house'
CVCV	/le:le/	'cradle'
CVCV	/la:ca/	'a sea bird'
CVCV	/lu:ro/	'flame'
CVCV	/leco/	'suck'

CVCV	/li:p ^h i/	'a tree'
CVCV	/rɛp ^h e:/	'meal'
CVCV	/rɔ:wɔ/	'boat'
CVCV	/bowa:/	'earth'
CVCV	/bo:t ^h o/	'cyclone'
CVCV	/p ^h ɛco/	'sword'
CVCV	/p ^h uro:/	'owl'
CVCV	/towa:/	'type of fish'
CVCV	/bɛ:mo/	'nightingale'

VCCV	/immɔ/	'husband, wife (terms of address)'
VCCV	/inno/	'water'
CVCCV	/cukbi/	'big tortoise'
CVCCV	/cerfo/	'fins'
CVCCV	/ji:lmo/	'sneeze'
CVCCV	/ji:rmu/	'land tortoise'
CVCCV	/kɔwbu/	'horse'
CVCCV	/rɛ:nmu/	'umbrella'
CVCCV	/mɔllo/	'eagle'
CVCCV	/ke:lla/	'god'
CVCCV	/rɛ:nmu/	'iron'
CVCCV	/mɔtto/	'road'
CVCCV	/mɔcco/	'hen'
CVCCV	/polmɔ/	'leech'
CVCCV	/p ^h atka/	'crow'
CVCCV	/tɔŋk ^h a/	'glass'

CVCCV	/tɔymo/	'grasshopper'
CVCCV	/t ^h urto/	'wirst'
CVCCV	/t ^h utbɔ/	'my stomach'
CVCCV	/nyure:/	'fish'
VCVC	/it ^h u:n/	'drop'
VCVC	/era:t/	'wing of bird'
VCVC	/ep ^h uk/	'lungs'
CVCVC	/bire:y/	'a bat'
CVCVC	/biyu:w/	'light'
CVCVC	/bu:ruŋ/	'hill'
CVCVC	/p ^h orɔ:c/	'house'
CVCVC	/ta:to:m/	'ground'
CVCVC	/te:reŋ/	'whole fish'
CVCVC	/t ^h ɛtɔŋ/	'whole hand'
CVCVC	/t ^h ume:l/	'honey'
CVCVC	/t ^h ijɔm/	Well decorated house'
CVCVC	/t ^h ip ^h ul/	'bed cover'
CVCVC	/t ^h ip ^h oŋ/	'iron rod to dig with'
CVCVC	/t ^h atat/	'my tongue'
CVCVC	/ɖula:w/	'ghost'
CVCVC	/jicər/	'rain'
CVCVC	/jurɔ:y/	'dance'
CVCVC	/jibe:t/	'swallow bird'
CVCVC	/ke:liw/	'whirlpool'
CVCVC	/kara:y/	'black ant'
CVCVC	/kaʃa:n/	'stars'
CVCVC	/kɛreŋ/	'whole fish'
CVCVC	/khide:r/	'coconut'
CVCVC	/miri:t/	'pigeon'
CVCVC	/mɔ:rɔk/	'an oyster'
CVCVC	/nyu.re/	'fish'
CVCVC	/lufuy/	'deep'
CVCVC	/lesar/	'dark'

CVCCVC	/t ^h irbin/	'my forehead'
CVCCVC	/t ^h ertek/	'my waist'
CVCCVC	/t ^h erlot/	'my stick'
CVCCVC	/t ^h ertap/	'my chin'
CVCCVC	/t ^h erbu:t /	'my ears'
CVCCVC	/t ^h erk ^h um/	'shoulder joint'
CVCCVC	/cɔmɔm/	'suparee tree'
CVCCVC	/kɔtp ^h e:c/	'earthen pot'
VCCVC	/etto:p/	'cover'
VCCVC	/ettay/	'blood'
VCCVC	/etcow/	'fruit of tree'
VCCVC	/ullu:y/	'whistle'

Trisyllabic

Open

VCVCV	/inora/	'bucket'
VCVCV	/i:mulu/	'egg'
VCVCV	/i:jilu/	'cold thing'
VCVCV	/i:jiyo/	'lowest tide'
VCVCV	/eluru/	'flame'
VCVCV	/eka:t ^h u/	'sprouting seeds'
VCVCV	/ɛno:re/	'cut'
VCVCV	/ɛrɔne/	'coral flower'
VCVCV	/ɛt ^h a:rɔ/	'male'
VCVCV	/ulu:fu /	'cobra'
VCVCV	/uluwe:/	'fountain'
VCVCV	/uba:lɔ/	'aeroplane'
CVCVCV	/bərəbə/	'mat'
CVCVCV	/p ^h ɔtɔle/	'spear'
CVCVCV	/p ^h orubi/	'frog'
CVCVCV	/tʌtʌmo/	'lizard'
CVCVCV	/t ^h ɛbala/	'elbow'
CVCVCV	/t ^h ɛp ^h ilu/	'my stomach'

CVCVCV	/t ^h umɔʔ/	'my feet'
CVCVCV	/t ^h emeca/	'my liver'
CVCVCV	/t ^h umɔʔo/	'leg'
CVCVCV	/t ^h i:mik ^h u/	'forest'
CVCVCV	/t ^h erulu/	'my eyes'
CVCVCV	/t ^h eri:nɔ/	'tears'
CVCVCV	/dɔlemo/	'big lizard'
CVCVCV	/cayo:ne/	'oil'
CVCVCV	/ca:lemo/	'black snake of the ocean'
CVCVCV	/juruwa:/	'sea ghost'
CVCVCV	/kala:bo/	'cockroach'
CVCVCV	/ko:nkuro/	'full hand'
CVCVCV	/kɔroʃo/	'necklace'
CVCVCV	/koburo/	'old umbrella'
CVCVCV	/lurup ^h e/	'air bubble'
CVCVCV	/lure:mo/	'rope'
CVCCVCV	/tutɕi:lo/	'island'
CVCCVCV	/t ^h ernoko/	'my checks'
CVCCVCV	/t ^h erkɔʔ/	'my nose'
CVCCVCV	/t ^h uŋkar:ra/	'my nails'
CVCCVCV	/t ^h uŋkuro/	'my palm'
CVCCVCV	/t ^h ukca:ra/	'my chest'
CVCCVCV	/t ^h umrɔnɔ/	'my ankle'
CVCCVCV	/t ^h erna:mo/	'mole on check'
CVCCVCV	/t ^h ermine/	'my brain'
CVCCVCV	/carrolol/	'parrot'
CVCCVCV	/ca:yʔolo/	'flower'
CVCCVCV	/litk ^h emo/	'water frog'
CVCCVCV	/mɔtkəbɔ/	'skin'
CVCCVCV	/si:rbele/	'waist belt'
CVCCVCV	/cɛletmu/	'bread'
CVCCVCV	/juro:ybe/	'dance'

CVCCVCV	/kolɛwbe/	'laugh'
CVCCVCV	/krinkɔ:so/	'strait island'

Closed

CVCVCVC	/so:yatec/	'a leaf'
CVCVCVC	/p ^h ɔ:rəʔɔŋ/	'bamboo tree'
CVCVCVC	/p ^h u:doʔɔŋ/	'palm tree'
CVCVCVC	/p ^h oro:ke:t/	'heaven'
CVCVCVC	/tokomeɫ ^h /	'pillow'
CVCVCVC	/tutumol/	'mosquito net'
CVCVCVC	/teremi:ɫ ^h /	'light'
CVCVCVC	/ɬɛkulul/	'boil'
CVCVCVC	/kɔp ^h oʔɔŋ/	'banana tree'
CVCVCVC	/re:ŋotɔŋ/	'peepal tree'
CVCVCVC	/pərain/	'water shower'
CVCVCVC	/biuɔc/	'torch light'
CVCVCVC	/caecɔn/	'hammer'
CVCVCVC	/niopɔŋ/	'jail'
CVCVCVC	/ni:ak ^h om/	'stone cave'
CVCVCVC	/mieteŋ/	'darkness'
CVCVCCVC	/teremlɔʔ/	'stick'
CVCVCCVC	/ta:rboriŋ/	'aeroplane'
CVCVCCVC	/ɬɔylocoŋ/	'deer'
CVCVCCVC	/ɬɔ:terbec/	'cloud'
CVCVCCVC	/kəllaʔɔp'/	'snail'
VCVCVC	/e:coʔɔy/	'skull bone'
VCVCVC	/i:jeyɔm/	'falling tide'
VCVCVC	/irulu:c/	'cold'
VCCVCCVC	/ettaycow/	'kidney'
CVCVCVV	/ɬɔk ^h tei/	'money'
CVCVCVCV	/ɬu:lɔka:ra/	'half moon'

CVCCVCVCV	/cukbitima/	'small tortoise'
CVCCVCVCV	/kona:su:bi/	'jungle snake'
CVCVCVCCV	/korɔbittu/	'centipede'
CVCVCVCCV	/ka:ytatoko/	'jack fruit'
CVCVCVCCV	/la:ɔcoŋe/	'a bird'
CVCVCVCCV	/ma:rojugu/	'honey bee'
CVCVCVCCV	/mɔcot ^h aro/	'cock'
CVCVCVCCV	/miaitucu/	'tomato/lemon'
CVCVCVCCV	/bilurɔ:wɔ/	'rainbow'
CVCVCVCCV	/tɔrabollo/	'type of fish'
VCVCVCV	/i:k ^h tɔlo/	'flower'

Closed

CVCVVCCVC	/pəroinŋɔŋ/	'bread'
CVCVVCCVC	/beitarɔm/	'cork'
CVCVVCCVC	/tʰiterephɔŋ/	'fish'
CVCVVCCVC	/tʰak ^h otoŋɔm/	'branch'
CVCVVCCVC	/tʰiterephɔŋ/	'pits'
CVCVVCCVC	/dʒi:ci:liŋɔŋ/	'sugarcane tree'
CVCVVCCVC	/caebeliŋ/	'cutter'
CVCVVCCVC	/lujiro:yɔm/	'dance'
CVCVVCCVC	/remutaca:n/	'trishul'
CVCVVCCVC	/urmukuruc/	'big house'
CVCVVCCVC	/i:p ^h ilekɔm/	'rising tide'
CVCVVCCVC	/inoterphɔŋ/	'well'
VCVCVCV	/ebuŋufe/ ɾ	'woman'

Pentasyllabic

Open

CVVCVCVV	/caetɔŋei/	'pocket'
CVVCVCVCV	/caetajira/	'chilly'
CVCVCVCVCCV	/penot ^h isorɔ ^h i/	'cot'

CVCVVCVCV	/bireitɛə/	'leaves'
CCVCVCVCV	/tɔk ^h otokata/	'piece of wood'
CVCCVCVCCVCV	/t ^h ɛrcotutɔmo/	'cap'
CVCVCVCVCV	/sareka:tiyo/	'sea crocodile'
CVVCVCVCV	/neɔtokəta/	'stone chip'
VCCVCVCVCV	/erconimik ^h a/	'bell'
VCVCVCVCV	/əra:tupulu/	'lamb'

Close

CVCVCCVCVCVC	/thitermɔlobum/	'straight line'
CVCVCVCVCCVE	/dɪk ^h i:lɪtutbək/	'joints between sugarcane'
CVVCVCVCVC	/neɔtataŋ	'roof'
VCVCCVCCVCVC	/əka:nternəkom/	'rinsing mouth'

Hexasyllabic

Open

CVCVCCVCVCCVCV	dɪ:leʃmututkətal/	'ball'
CVVCVCVCVCV	/niuteroloʃə/	'window of house'
CVVCVCCVCVCCV	/dɪ:utuntəra:llɛ/	'west'
CVCVCCVCCVCCVCV	/tutumrəŋtutjɪlu/	'shawl'
CVCVCVCVCVCV	/tɔkotərə:bucu/	'Root of tree'
CVVCVCCVCVCV	/dɪ:utuntəkara/	'east'
VCVCVCCVCVCV	/i:k ^h ubintɔlokə/	'flower bloom'

Close

CVCVCVCVCVCVC	/t ^h erulutudirim/	'pupil'
CVCVCCVCCVCVCVC	/miyaytuʃeulog ɔm/	'tamarind tree'
CVCVCCVCCVCVCCVCVC	miyaytuʃkattaʃ ɔn/	'lemon tree'

Septasyllabic

Open

CVCVCVCVCVCVCV	/ŋɔma:ʧtara:towɔ/	'your heel'
CVCVCVCVCVCCVC V	/ʧebura:culutt ^h u:we/	'my wife's brother'

Closed

VCCVCVCVCVCVC	/akka:mimitara:ʧɔŋ/	'queen'
CVCCVCVCCVVCVC	/pirta:rɛycopoba:lɔŋ/	'rainbow'

CHAPTER FOUR

Summary and Conclusion

This present study has therefore attempted to detail and describe the speech sounds of Andamanese. The Andamanese group of languages is at present nearly on the verge of extinction. As in May, 1993, only 32 native speakers of this language remained. It is, therefore, absolutely essential to undertake a detailed linguistic study of this indigenous language before it is too late. Although the present study has been limited due to several factors, I hope it has achieved one of its objectives in providing a starting-point for further research.

One of the major limitations I faced while conducting this study was the total absence of any primary data collected on the basis of proper preparation--preparing questionnaire, basic word-list etc. -and most importantly, through personal fieldwork. These steps are crucial, especially in such data based research because each researcher has his/her own area of focus while conducting a study. Unfortunately I could not undertake any fieldwork due to paucity of time and financial constraints, and, as a result, had to rely primarily on secondary sources of data, in particular, the four cassettes recorded from the laboratories at CIIL, Mysore, data collected by my supervisor during her fieldtrip, and S. Manoharan's basic word list in his work, *A study of Andamanese*

Language. This data was transcribed using the International Phonetic Alphabet symbols, following which it was rechecked a number of times to minimize possibility of errors. After the process of transcription, the raw data was first categorised on the basis of initial sounds – for example – all the words beginning with /p/ were grouped as one. Following this, minimal and sub-minimal pairs were extracted, on the basis of which phonemic chart for vowels and consonants were made. Each phoneme was further classified on the basis of occurrence in different positions, i.e. initial, medial and final, and phonetic and phonological analysis was done.

The analysis of data show that the phonemic system of Andamanese is made up of thirty two segmental phonemes. Of these twenty four are consonants and eight are vowels.

Stops:

There are twelve stop consonant phonemes in this language. They are

represented by /p/, /b/, /p^h/, /t/, /d/, /t^h/, /t̪/, /d̪/, /t̪^h/, /k/, /g/, and /k^h/.

/p/ is a voiceless unaspirated bilabial stop. Regarding its distributions, it

occurs in all the positions.

/b/ is a voiced unaspirated bilabial stop. Regarding its distributions, it occurs only in two positions, viz, initial and medial.

/p^h/ is a voiceless aspirated bilabial stop. Regarding its distributions, it occurs in only two positions, viz, initial and medial.

/t/ is a voiceless unaspirated alveo-dental stop. Regarding its distributions, it occurs in all the positions, viz, initial, medial and final.

/d/ is a voiced unaspirated alveo-dental stop. Regarding its distributions, it occurs only in two positions, viz, initial and medial.

/t^h/ is a voiceless aspirated alveo-dental stop. Regarding its distributions it occurs only in two positions, viz, initial and medial. Regarding its distributions it occurs only in two positions, viz, initial and medial.

/ʈ/ is a voiceless unaspirated retroflex stop. Regarding its distributions, it occurs in all the positions, viz, initial, medial and final.

/ɖ/ is a voiced unaspirated retroflex stop. Regarding its distributions, it

occurs only in two positions, viz, initial and final.

/t^h/ is a voiceless aspirated retroflex stop. Regarding its distributions, it

occurs in all the positions, viz, initial, medial and final.

/k/ is a voiceless unaspirated velar stop. Regarding its distributions, it occurs in all the positions, viz, initial, medial and final.

/g/ is a voiced unaspirated velar stop. Regarding its distributions, it occurs in only one position i.e. initial.

/k^h/ is a voiceless aspirated velar stop. Regarding its distributions, it occur only in two positions, viz, initial and final.

Affricates: There are only two affricate consonant phonemes in this language- /c/ and /j/.

/c/ is a voiceless unaspirated palatal affricate. Regarding its distributions, it occurs in all the positions, viz, initial, medial and final.

/j/ is a voiced unaspirated palatal fricative. Regarding its distributions it occurs only in two positions, viz, initial and medial.

Nasals: There are four nasal consonant phonemes in this language:-

/m/, /n/, /ɲ/ and /ŋ/.

/m/ is a voiced bilabial nasal. Regarding its distributions, it occurs in all the positions, viz, initial, medial and final.

/n/ is a voiced alveolar nasal. Regarding its distributions, it occurs in all the positions, viz, initial, medial and final

/ɲ/ is a voiced alveolar nasal. Regarding its distributions, it occurs in all

the position, viz, initial, medial and final.

/ŋ/ is a voiced velar nasal. Regarding its distributions, it occurs in all the positions, viz, initial, medial and final.

Liquids: There are two liquids in this language- /r/ and /l/.

/r/ is a voiced alveolar trill. It occurs in all the positions, viz, initial, medial and final.

/l/ is a voiced alveolar lateral. Regarding its distributions, it occurs in all the positions, viz, initial, medial and final.

Fricative: There are three fricatives in this language- /s/, /ʃ/ and /h/.

/s/ is a voiceless alveolar fricative. Regarding its distributions, it occurs in only two positions, viz, initial and medial.

/ʃ/ is a voiceless palatal fricative. Regarding its distributions, it occurs in all the positions, viz, initial, medial and final.

/h/ is a voiceless post velar fricative. Regarding its distributions, it occurs only in one position- initial.

Semi-vowel: There are only two semi- vowels in this language-

/w/ and /y/.

/w/ is a voiced bilabial semi vowel. Regarding its distributions, it occurs in all the positions, viz, initial, medial and final.

/y/ is a voiced palatal semi- vowel. Regarding its distributions, it occurs in all the positions, viz, initial medial and final.

Further, the Andamanese language permits only sequence of two consonants. Words initial consonant sequence are not found in this language, with the exception of ny-. This language is marked by the absence of word final consonant sequence. However, word medial consonant sequences are found in abundance. The followings consonants :- /t/, /tʰ/, /k/, /c/, /s/, /m/, /n/, /ɲ/, /l/ and /r/ occurs as geminates consonant sequence in this language.

As far as vowels are concerned, eight vowels are recognized in this language.

/i/ is a short high front unrounded vowel. It occurs in all the positions.

/e/ is a short mid-front unrounded vowel. It occurs in all the positions.

/ə/ is a central unrounded vowel. It occurs in only two positions i.e. initial and medial.

/ɛ/ is a short unrounded lower mid-front vowel. It occurs in all the positions.

/a/ is a short unrounded low back vowel. It occurs in all the positions.

/ɔ/ is a short rounded lower-mid back vowel. It occurs in all the positions.

/o/ is a short rounded mid-back vowel. It occurs in all the positions.

/u/ is a short rounded high back vowel. It occurs in all the positions.

Nasalisation of vowel in Andamanese is not phonemic. But as the data shows some vowels get fully nasalised due to the influence of nasalised phonemic vowels in Port Blair Hindi. Vowel length in Andamanese is phonemic.

Diphthongization of vowel do to take place in this language and as the data show all the diphthongs ends with high front vowel /i/ except in one instance, when it ends with back high vowel /u/.

As far as the syllabic sequence of this language is concerned it ranged from one to seven. Further, the language is dominated by trisyllabic and tetryllabic word.

However I hope that this present study, in which I have tried to document the features of speech sounds in Andamanese, will go a long way in helping the language to survive, which is already on the verge of extinction. If given the opportunity in Ph.D., I would carry on with the incomplete work, and undertake detailed research on topics not covered in this study. I would first undertake a fieldwork in the area. This would not only give me an opportunity to live among and interact with the natives of the area, in addition it would also provide me with valuable insights into the language. On the basis of the data collected as well as secondary sources already available, a more detailed linguistic analysis would be undertaken. This would include a check of phonetic and phonological patterns, as well as analysis of sounds at morphological, semantic, syntactic and well as morphophonemic and morphosemantic levels- the ultimate aim being to compile a comprehensive linguistic volume of the language. Furthermore, spectrographic analysis would

also be undertaken, whereby; a broad general picture of the formant patterns of vowels as well as an acoustic pattern of consonants would be arrived at. However, to achieve this, it is imperative to have a large data-bank, which is only possible through primary sources.

In spite of such limitations, this study, has I hope, been of some use in documenting and analysing the linguistic features of these unique indigenous group of people. If, in any way, it inspires greater attention to be focused on these rapidly depleting tribes – in particular, on their language and culture, I will consider my endeavor a success.

BIBLIOGRAPHY

BIBLIOGRAPHY

- Abercrombie, David. *Elements of General Phonetics*. Edinburgh: Edinburgh University Press, 1967.
- Abrams, M.H. *A Glossary of Literary Terms*. Bangalore: Prism Books, 1993.
- Akmajian, Adrian, Richard. A Demers, Ann. K. Farnen Robert. M. Harnish eds. *Linguistics: An Introduction of Language and Communication*. New Delhi: Prentice-Hall, 1990.
- Allen, H.B.ed. *Some Methodoogical Remarks on Generative Grammar: Readings in Applied English Linguistics*.
- Anderson, S. *The Organisation of Phonology*. New York: Academic Press, 1974.
- Apresjan, J.D. *Principles and Methods of Contemporary Structural Linguistics*. The Hague, Paris: Mouton, 1973.
- Aronoff, Mark and Richard T. Cehrle. *Language, Sound Structure*. Cambridge: MIT Press, 1994.
- Asher, R.E. and Henderson, Eugence J.A. *Towards a History of Phonetics*. Edinburgh: Edinburgh University Press, 1981.
- Black, Bernard, and George L. Trager. *Linguistic Analysis*. New Delhi: Oriental Books, 1942.
- Brosnahan, L.F. and Bertil, Malmberg. *Introduction to Phonetics*. Cambridge: Waheffer and Sons Ltd., 1970.
- Carr, Philip. *Phonology*. Basingstoke:Macmillan, 1993.
- Catford, J.C. *Fundamental Problems in Phonetics*. Edinburgh: Edinburgh University Press, 1982.

- Chafe, W. *Meaning and Structure of Language*. Chicago: University of Chicago Press, 1970.
- Chakraborty D.K. *The Great Andamanese: Struggling for Survival*. Calcutta: Seagull Books, 1990.
- Crystal, David. *A First Dictionary of Linguistics and Phonetics*. Cambridge: 1980.
- Dasgupta, D and S. R. Sharma. *A Handbook of Onge Language*. Calcutta: Anthropological Survey of India, 1982
- Dutta, P.C. *The Great Andamanese: Past and Present*. Calcutta: Anthropological Survey of India, 1978.
- Fudge, Erick C. *Phonology*. Middlesex: Penguin Books, 1973.
- Garvin, Paul. *On Linguistic Method: Selected Papers*. The Hague, Paris: Mouton, 1972.
- Gleason, H.A. *An Introduction to Descriptive Linguistics*. New Delhi: Oxford and IBH Publishing Co., 1968.
- Harris, Zellig. *Structural Linguistics*. Chicago: University of Chicago Press, 1960.
- Hockett, C.F. *A Course in Modern Linguistics*. New Delhi: Oxford and IBH Publishing Co., 1958.
- Hyman Larry M. *Phonology- Theory and Analysis*. New York: Harcourt Brace Jaranovich College Publishers, 1975.
- Jakobson, R., G.M. Fant, and Halle, M. *Preliminaries to Speech Analysis*. Massachusettes: MIT Press, 1963.
- Kibrick, A.E., *The Methodology of Field Investigation in Linguistics*. The Hague, Paris: Mouton, 1977.
- Kothari, C.R. *Research Methodology: Methods and Techniques*. New Delhi: Wishwa Prakashan, 1995

- Koul, Omkar. N. ed. *Vartavaha*. Vol. 6, September 2000. Mysore: Central Institute of Indian Languages, 2000.
- Kovacs, Ferenc. *Linguistic Structure and Linguistic Laws*. Budapest: Akademiai Kiado, 1981.
- Ladefoged Peter. *A Course in Phonetics*. New York: Harcourt Brace and Jovanovich, 1975.
- Ladefoged, Peter. *Preliminaries to Linguistics Phonetics*. Chicago: University of Chicago Press, 1973.
- Laver, John. *The Phonetic Description of Voice Quality*. Cambridge: Cambridge University Press, 1980.
- Lyons, J. *Introduction to Theoretical Linguistics*. Cambridge: Cambridge University Press, 1968.
- Lyons, John. *New Horizons in Linguistics*. Middlesex: Penguin Books, 1970.
- Maddison, Ian. *Patterns of Sounds*. Cambridge: Cambridge University Press, 1984.
- Mann E.H. *On the Original Inhabitants of the Andaman Islands*. London: Royal Anthropological Institute, 1932 (reprint).
- Manoharan S. *Study of Andamanese Language*. Calcutta: Anthropological Survey of India, 1989.
- Mouat F.J. *Adventures and Research among the Andaman Islanders*. London: Hurst and Blackott, 1863.
- Narang, Vaishna. *Communicative Language Teaching*. New Delhi: Creative Books, 1996.
- Pike, Kenneth L. *Phonetics: A Critical analysis of Phonetic Theory and Technique for the Practical Description of Sounds*.
- Portman, M.V. *Manual of the Andamanese Language*. Delhi: Manas Publication, 1992 (reprint).

- Radcliffe, Brown, A.R. *Andaman Islanders*. New York: Free Press, 1922/1964.
- Sarkar, Jayanta. *The Jarawa*. Calcutta: Seagull Books, 1990.
- Schane, Sanford. A. *Generative Phonology*. New Jersey: Prentice Hall, 1973.
- Sharma, D.D. *A Descriptive Grammar of Kinnauri*. Delhi: Mittal Publications, 1988
- T. Thangaswamy, M.A. *Glimpses of History: Pre 1908 Andaman and Nicobar Islands*. Port Blair: Swamy Publishers, 1996.
- Tamta, B.R. *Andaman and Nicobar Islands*. New Delhi: National Book Trust.
- Trask, R.L. *A Dictionary of Phonetics and Phonology*. London: Routledge, 1996.
- Varshney, R.L. *An Introductory Textbook of Linguistics and Phonetics*. Student Store.

APPENDICES

penot ^h isort ^h i	cot
pərain'	water shower
pirta:reycopoba:lən	rainbow
pa:lɔuwo	big wave
pɔ:r	bamboo
purummomyo	big rock
pe:c	utensils
pi:r	a cane
bilurɔ:wə	rainbow
bire:y	a bat
bi:p	dust
biyu:w	light
bɛ:mo	nightingale
bu:ruŋ	hill
bolmɔ	leech
bowa:	earth
bo:t ^h o	cyclone
ba:tterkɛ:l	mid-night
bərabə	mat
beitarəm	cork
bol	rope
bireitɛcə	leaves
biumɔc	torchlight

be:mo	butterfly
billubira:ncəbo	rainbow
bu:ruin	mountain
bu:ruintutlup ^h ui	big/high mountain
bu:liu	river/canal
Buliucor	water falling from dam
buliututərakatterp ^h enne	bridge
bi:lu	ship
bəra:ba	mat
bei	bottle
beituntəplo	one bottle
beitatirbui	two bottles
bəra:ba:tcuʔə	rounding the mat
p ^h εc ^h	pot
p ^h εco	sword
p ^h ətole	spear
p ^h aʔka	crow
p ^h ə:rəʔəŋ	bamboo tree
p ^h u:doʔəŋ	palm tree
p ^h a:l	wave
p ^h uro:	owl
p ^h u:	cow dung
p ^h on	cave

phormuca:w	lion, tiger
p ^h orɔ:c	house
p ^h orɔ:ke:t	heaven
p ^h orubi	frog
teremlɔʈ	stick
tokomet ^h	pillow
tutumol	mosquito net
teremit ^h	light
tanʈɔ	necklace
tutumɔl	fan
ta:to:m	ground
terɛŋk ^h ulitiʃuta:to:m	playground
təra:mluk ^h imi	balance
taji:beɔr	fish
te:reŋ	whole fish
to:tp ^h ollo	beach
tutɟi:lo	island
te:ɔ	crocodile
tərabollo	type of fish
towa:	type of fish
terɛŋ	whale
ta:p ^h o	type of tree
tirpile:ʃɔt'	all teeth

tirpile:tintəplə	one teeth
tirpile:tatirbui	two teeth
teremi:t ^h	light
teremi:t ^h tuntəplə	one light
teremi:tatirbui	two light
təŋk ^h u:	glass
təŋk ^h u: tuntəplə	one glass
təŋk ^h utatirbui	two glasses
ta:rboriŋ	aeroplane
ta:rboriŋtuntəplə	one aeroplane
ta:rboriŋtatirbui	two aeroplanes
tajeitudbekbijugun	bird fly
tajeitudbektuntəpləbijugun	one bird fly
tajeitudbektatirbuibijugun	two birds fly
tajeitudbekcəp ^h ebijugun	many birds fly
termoltərciɬallo	zig-zag line
teremləɬ	stick
tokomeɬ ^h	pillow
tutumol	mosquito net
t ^h ercyək	my face
t ^h irbin	my forehead
t ^h ernoko	my cheeks

t ^h ergilitubεc	my eyebrow
t ^h erulutukōhō	my eye lids
t ^h erulutudirim	pupil
t ^h erkōtō	my nose
t ^h erjuk ^h ubεc	my moustache
t ^h i:bel	broom
t ^h oru:be	frog
t ^h εi	cooking utensil
t ^h erʔaotuntōplo	sign of one feet
t ^h erʔaotatirbui	sign of two feet
ʔōktisetencir	bathing soap
ʔutumrōŋʔutgilu	shawl
ʔəudε	rat
ʔəylocoŋ'	deer
ʔεle	elephant
ʔεletirkōt ^h o	elephant trunk
ʔεletirp ^h i:lle	elephant tusk
ʔoymo	grasshopper
ʔaʔamo	lizard
ʔe:p ^h i	land lizard
ʔōŋleo	small tree
ʔōkotərə:buco	root of tree

တၢ်တၢ်တၢ်	tree branch
တၢ်က ^h တၢ်တ	tree leaves
တၢ်က ^h တၢ်တကတ	piece of wood
တၢ်တၢ်တၢ်တ ^h တၢ်	shade of tree
တၢ်တၢ်တၢ်	cloud
တၢ်က ^h တၢ်တၢ်တ	branch
တၢ်တၢ်	potato
တၢ်တ ^h တၢ်	octopus
တၢ်တၢ်တၢ်	wife
တၢ်တၢ်တၢ်	cap
တၢ်တၢ်	bath
တၢ်တၢ်	turtle
တၢ်တၢ်	gold
တၢ်တၢ်တၢ်	lizard
တၢ်တၢ်တၢ်	cloud
တၢ်တၢ်	sky
တၢ်တၢ်	sand
တၢ်တၢ်တၢ်တၢ်	one finger
တၢ်တၢ်တၢ်တၢ်	two finger
တၢ်တၢ်တၢ်တၢ်	sleeper
တၢ်တၢ်တၢ်တၢ်တၢ်	one sleeper

ṭumətotattaloṭatirbui	two sleeper
ṭək ^h otei	money
ṭək ^h oteituntəplo	one rupee
ṭək ^h oteiktirbu	small change
ṭ ^h εṭəŋ	whole hand
ṭ ^h εbala	elbow
ṭ ^h urto	wrist
ṭ ^h uŋkuro	my palm
ṭ ^h uŋkinəp	my finger
ṭ ^h uŋka:ra	my nails
ṭ ^h ukca:ra	my chest
ṭ ^h εp ^h ilu	my stomach
ṭ ^h εŋge:t ^h	my
ṭ ^h εrtək	my waist
ṭ ^h εcəpt ^h umo	my thigh
ṭ ^h əraməṭə	my leg
ṭ ^h εəəək	my knee
ṭ ^h uməṭə	my feet
ṭ ^h umrəno	my ankle
ṭ ^h uməṭəṭumik ^h u	sole of feet
ṭ ^h utbə	my stomach

t ^h ɛrna:mo	mole on cheek
t ^h ɛrinoe	open
tɛkulul	boil
t ^h ɛrmine	my brain
t ^h utbɔrtudilo	my heart
t ^h utkɔrno	my lungs
t ^h e:ʃɔu	my
t ^h emeca	my liver
t ^h ɛrcotut t ^h ɔmo	cap
t ^h ucu tucu	my turban
t ^h ɛrkɔt ^h ɔjum	nose ring
t ^h ɛrbu:jum	ear ring
t ^h umɔto	leg
t ^h ɛrlɔt	my stick
t ^h ijɔm	well-decorated house
t ^h i:mik ^h u	forest
t ^h ume:l	honey
t ^h iterep ^h ɔŋ	pits
t ^h erulu:tatirbui	two eyes
t ^h erulu:tuntɔplo	one eye
t ^h a:tɔ	house

t ^h a:totuntɔplɔ	one house
t ^h a:tɔtatirbui	two houses
t ^h ɔkotərace t ^h o	root of trees
t ^h ɔkotərace t ^h otuntɔplɔ	one root of tree
t ^h ɔkotərace t ^h otatirbui	two roots of trees
t ^h utneɔ	my house
t ^h iterdɪt ^h	gap in the wall
t ^h ip ^h ul	bed cover
t ^h itermɔl	pen/pencil
t ^h itermɔlobum	straight line
t ^h ip ^h oŋ	iron rod to dig with
t ^h εco	my head
t ^h erulu	my eyes
t ^h eri:nɔ	tears
t ^h εrbua	my lips
t ^h atat	my tongue
t ^h εrpili	my tooth
t ^h εrpiletərat ^h ərale	my gum
t ^h εrtap	my chin
t ^h εrtapebeic	my beard
t ^h erbu:t	my ears

t ^h utlɔŋgo	my neck
t ^h ɛr ^h a:ra	my parting of hair
t ^h ut ^h beic	my hair
t ^h ut ^h beitərakət ^h	long pant
t ^h ɛrɫalar	bald head
t ^h utɫalar	i am bald
t ^h erk ^h um	shoulder joint
t ^h yɔtɔy	shoulder blade
t ^h i:taŋɔroioɫuncuimo	house lock
t ^h i:taŋɔroioɫuncuimoturtɔplɔ	one house lock
ɖole:mo	big lizard
ɖi:ci:liɫɔŋ	sugarcane tree
ɖik ^h i:litokatta	piece of sugarcane
ɖik ^h i:litutbɔk	joints between sugarcane
ɖi:u	sun
ɖu:llɔ	moon
ɖi:utuntəkara	east (sunrise)
ɖi:utuntəra:llɛ	west (sunset)
ɖi:de	noon
ɖi:dettecla:w	jungle ghost
ɖo:lemo	squirrel

du:loka:ra:	half moon
du:m	centipede
dup	gingham tree
dula:w	ghost
di:leʔmututkəta	ball
di:leʔmututkətatunəplə	one ball
di:leʔmututkətatirbui	two ball
dile:ʔmutirk ^h uru	big ball
dile:ʔmuleo	small ball
kolɛwbe	laugh
kona:su:bi	jungle snake
kurude	thunder
ke:r	snore
ke:liw	whirlpool
ko:t	laugh
kəʔp ^h e:c	earthen pot
kəʔmərə:y	white ant
krinkə:so	strait island
ka:kə	banana tree
kala:bo	cockroach
kara:y	black ant
kaʔa	daughter

ɖu:lɔkɑ:rɑ:	half moon
ɖu:m	centipede
ɖup	gingham tree
ɖula:w	ghost
ɖi:lɛʈmututkəta	ball
ɖi:lɛʈmututkətatunəplə	one ball
ɖi:lɛʈmututkətatirbui	two ball
ɖile:ʈmutirk ^h uru	big ball
ɖile:ʈmuleo	small ball
kɔlɛwbe	laugh
kɔnɑ:su:bi	jungle snake
kurudɛ	thunder
ke:r	snore
ke:liw	whirlpool
ko:t	laugh
kəʈp ^h e:c	earthen pot
kəʈmərə:y	white ant
krinkə:so	strait island
ka:kə	banana tree
kala:bo	cockroach
kara:y	black ant
kaʈa	daughter

kaʔa:n'	stars
ko:lɔ	eagle
kɔwbu	umbrella
kɔrɔbittu	centipede
kɔca:	cycle
kɔp ^h ɔʔɔŋ	banana tree
ko:nkuro	full hand
kɔrɔ:so	necklace
kɔrɔ:sotuntɔplɔ	one necklace
kɔrɔ:sotatirbui	two necklace
koʔ ^h urɛmo	pan
kɔp ^h o	banana tree
kɔp ^h o tucu	banana fruit
ko	bow
koeto	jackfruit
kɔllo	eagle
ke:lla	god
ke:reŋ	whole fish
kɔemo	ant
kəllaʔɔp'	snail
koytɔʔɔŋ	jackfruit tree
katɔn	star
ke:o	small crab

ka:yttə	jackfruit tree
ka:ytatoko	jackfruit
ka:mə	type of potato
koburə	old umbrella
kobuk ^h ui	new umbrella
kərajpulcayti ^h itəraulle	far things look near
katsaregbanno	he makes tea
k ^h idirtat ^h u	coconut
k ^h idi:rtərtec	coconut water
k ^h idi:rtutkəvo	outer covering of coconut
k ^h idi:rtutco	coconut fruit
k ^h idi:rtəŋ'	coconut tree
k ^h ide:r	coconut
k ^h i:nə	grass
k ^h idi:rtəy	coconut shell
k ^h ɛŋe:	cat
k ^h ɛŋe:tuntəplə	one cat
k ^h ɛŋetatirbui	two cat
k ^h idirtəŋ	coconut tree
k ^h ɛŋeleo	small cat
k ^h idjica:ywe	what is this
k ^h ələtəmorəʃue	makes chappati

k ^h eŋet ^h irk ^h uru	big cat
ca:y ^t əra:luktisioremo	weight balance
carolo	parrot
cukbi	big tortoise
cukbitima	small tortoise
cəmtə ^m	'suparee' tree
ca:y ^t əlo	flower
cokbi:	fins
ce	thorn
ceŋo	sneeze
cel	water falls
ce:yo	knife
caytaŋə ^t ^h	bag
caebelŋ	cutter
caetajira	green chilly
caecə ⁿ	hammer
cəletmə	bread
cayo:ne	oil
ca:lemo	black snake of the ocean
cowa:	type of fish
cokbi:	fins
caetə ^t ei	packet
caetə ^t eituntəplo	one packet

caetəʔeicəp ^h e	many packet
ca:yʔ ^h i:tiʔ ^h u	pulling cart
ca:yʔ ^h i:tiʔ ^h utuntəplə	one pulling cart
julu	clothes
ji:lmo	land tortoise
jicəɾ	rain
jo	song
juruwa:	sea ghost
jurə:ybe	dance (v)
jurə:y	dance
je:t ^h o	a sea snake
jemo	a shark
jibe:t	swallow bird
ji:ɾmu	horse
jero	papaya tree
ji:li	father's brother's wife
jubu	fly
sareka:tiyo	sea crocodile
su:bi	snake
si:ro	ocean
sa:re	sea
su:p	basket
so:yatec	a leaf

sulu	type of fruit
si:rbele	waist belt (male)
Subi	snake
Subituntəplə	one snake
həletəracol	light
himolterceʔalo	zig-zag line
hirk ^h doe	round
hitkəʔ ^h a	circle
hutk ^h udoe	globe
Mino	potato
Miaitucu	tomato/lemon
Miailobəŋ	tamarind
mətto	road
məcco	hen
məcot ^h aro	cock
Miri:t'	pigeon
Miyaytuʔculogəm'	tamarind tree
Miyaytuʔkattaʔəŋ	lemon tree'
Mietəŋ'	darkness
mətkəbə	skin
mətətəi	breast
mi:nə	type of potato
Myo	rock

ma:ye	father
ma:r	a fish
ma:rɔ	honey bee
mɔycammulu	egg
mu:r	foam
Mettaymul	milk
mɔcɔ	hen
mɔcɔtuntɔplɔ	one hen
mɔcɔtatirbui	two hen
ma:rojugu	honey bee
ma:rojugutuntɔplɔ	one honey bee
ma:rojutatirbui	two honey bees
mɔ:rɔk	an oyster
neɔ	house
neɔtokɔta	stone chip
neɔtɔratɔŋ	roof
neɔtakuŋ	door of house
Niuteroloʈɔ	window of house
Netibenukanɛulitasojiyo	thermometer
Netibinosɔrokajiyo	injection
Niopoŋ	jail
Nyu:re	fish
ni:p ^h o	small mosquito

ni:aok ^h om	stone caves
ni:aok ^h omtumkotmətəbe	way through caves
Niyatucu	piece of stone
Nucaərtiɖəm	people are seeing
no:cotatirbui	two houses
no:cə	house
no:cotuntəplə	one house
le:le	cradle
lɛc	arrow
Laotəkəratəŋ	skeleton
Lujiro:yəm	dance
le:	land crab
liṭk ^h emo	water frog
lɛ:c	weapon to kill fish
Lim	a sea stone
la:wp ^h an	betel leaf
la:w	outsider, ghost
la:ca	a sea bird
la:wəcoṭe	a bird
lo:l	there
Loyətto	pumpkin
Lurup ^h e	air bubble
lu:ro	flame

Lure:mo	rope
luʃuy	deep
lɛsar	dark
lɛco	suck
Lere:mo	white sand fly
Le	smoke
li:p ^{hi}	a tree
li:ṭṭu	a fish
lɛ:ctunṭpḷo	one arrow
lɛ:ctatirbui	two arrows
Labuk ^h umoṛcitalọṭa	wearing saree
rɛp ^{he} :	meal
Remutaca:n	trishul
ra	pig
re:ŋọṭọŋ	peepal tree
re:k	big crab
rɛ:nmu	iron
ṛo:ẉo	boat
ro:wsu	kokkari fish
wera:kuikom	smokes cigarette
weta:rk ^h aiḍqueson	listening to radio
Idroṃṭəy	bone
Inoterp ^h ọŋ	well

Itolotoe	horn
Inora	bucket
Itbe:c'	dal
Ili	urine
Immo	husband, wife (term of address)
Issu:ye	burn
ijo:kke	eat
Inovita ^h acɔr	water that falls
i ^h u:n	drop
Irulu:c	cold
i:k ^h u ^t ɔlo	flower bud
i:k ^h ubin ^t ɔloko	flower bloom
i:k ^h u ^t ɔllo	flower
i:mututtəralakan ^t ɔya	standing on this
i:mulu	egg
i:p ^h ilekəm	rising tide
i:jeyəm	falling tide
i:nno	water
i:r	wave
i:jilu	cold thing
i:jiyö	lowest tide
i:jilikmo	tiny one
Eluru	flame
Erconi/mik ^h a	bell

Eka:t ^h u	sprouting seeds
erʈɔ:ŋtutke	thorn in branch
era:ʈ	wing of bird
Erka:ra	tiny
Ebuʃuʃe	woman
Etto:p	cover
Ettay	blood
Ecco:wbe	built house
Ecca:ʃa:nɔ	old man
ep ^h uk	lungs
Etcow	fruit of tree
Etkɔwbo	bark of trees
eŋmɔcom	scratching
ere:ŋtɔŋetalɔʈa	putting hand into the shirt
e:coʈɔy	skull bone
e:toe	bone
ey	vomit
εwo:re	cut
εrɔne	coral flower
εmeycca:	liver
εt ^h a:rɔ	male
εttaylε:p	ovary

ɛttaycow	kidney
əɾəkəɾapɿœ	waist bone
əbɪlɪk ^h utɾɪo	prayer room/temple
ə:cao	dog
ərwə	boat
əbɪrɪccəo	wild cat
əra	pig
əkanyakom'	he eats
əkɑ:nɛrɾəkɔm'	rinsing mouth
əɾɑ:tubulu	lamb
əɾɑ:mbɪno	lying down
əkɑ:mɪmɪrɛp ^h ɪrakoɿ	mother gives the food
ə ^h ɪɛnɪsɪɛɾɑ:ncəɾoɪ	slipping
əkɑ:ɔnoɾokutumul	moving fan in sitting posture
əbuomɿtulum	beating drums
Uɾmu kuruc	big house
Ulluk ^h u	cobra
Uba:lɔ	aeroplane
urɔ:	an arrow
Ullu:y	whistle
Uluwe:	fountain
Uluʃu	cobra
ututtu:ne	sister's husband

Utkiye	pour out
Utbuliya:	feast
Utbeilo	wooden plank
undujiro:l	shivering
Urcə	net
Ulitəracər	shower
Uinok ^h u:m	drinks water
u:ntɛla:m'	calling
uju:sərəkəm	sing a song
Uca:yaʈəlokteŋum	listens to you
Ucayatuttəralakanʈaya	stands at the top
Uimututtralakaono	sitting upon that
ubi:no	sleeps
Utumisitakom	getting up from bed
Uile	shirt
Uca:ysisəɾə	grinding something
uk ^h ɛlɛ:ʈmu:sitə	grinding flour
Ucaybi:li	cutting something
uk ^h idiregər	scratching coconut
ui:nuʈe:n	takes water
ul:nukabere:ŋ	fill water
Ujuluci:r	wash clothes
Ujuludbi:n	rinse clothes

up ^h εcisi:r	clean utensils
uʃi:rbɛl	brooming
Unoši:r	clean the house
Ucaytajiratcittə	grinding spice
ut ^h untiretbecikabor	combing children's hair
ut ^h u:mbecirakεt	combing his hair
Uerkulup ^h u	putting utensils in the oven
Usumulcaytarck ^h o	keeping some thing on the top
Usumuttacaytalle	bring something down from top
uɖileʃmora: t ^h ulimi	playing with the ball
Ulille	swinging
utu:nt ^h iritalille	swinging her children
uɖile:ʃmutkətraʃ ^h ul	kicking the ball with leg
uɖile:ʃmorabat ^h imi	kicking the ball with hand
uɖile:ʃmoek	catching the ball
Uetajugum	flying something
uɖile:ʃtmukabora	throw big ball
Uektertulɔm	shooting arrow
Uiktirsirtətayratirikom	catch to kill
Ujuroyaŋ'	she dances
Uitlik ^h ukəm	make
ut ^h i:rp ^h oməm	digging the hole
Uiulutakat ^h u:m	sowing the seeds

uʔə:ŋleura meʔ ^h um	putting soil between the trees
uʔ ^h i:tberəŋəm	pouring water
Ueraluk ^h um	measuring
olo:ŋa	light
Ottekəkusire	remove
Otca:me	arrest
Otka:tta	short
oʔəŋgeralottəm	uprooting trees
Okop ^h aʔəm	pulling the bow
Oməʔəkəm	swims
oŋo:ʔap ^h oŋekayek ^h o	door opens at the top.
oŋo:kat ^h oke	shuts the door
okə:t ^h əm'	sneezes
o:prə	window
o:kra	type of fish
oroia:ra	type of flower
oro:nə	a sea snake
otkərnə	lungs
oro:ne	coral
oro	flower
ələ	axe
oco	net
otkərnə	lungs

ɔ:te:ɲom'	spits
ɔ:t ^h o	morning
ɔ:rsu:bi	black sea snake
ɔ:m	tree
a:le	light
a:t	fire
a:t t̄ermol	match box/match stick
a:t̄luru	fire
a:t̄lip	smoke
a:tcerep	axe
a:t̄d̄o:p	fire wood chips
a:t̄tara:bi:t̄te	fire place
a:p ^h otokoə	banana fruit
a:p ^h o	banana tree
a:t̄ta:co	bundle of woods
a:t̄ta:cotunt̄opl̄o	one bundle of woods
a:t̄ta:cotatirbui	two bundle of woods
a:t̄t̄erculueratesi	putting utensils on the oven

